

StarLPRO-1500

High-Precision & Performance Rubidium Source



User Manual

Document Part No: StarLPRO_1500_Manual

Revision: 071222

Contents

1.	INTRODUCTION	3
2.	STARLPRO-1500 SYSTEM DESCRIPTION	3
2.1	PRINCIPLE OF OPERATION AND BASIC CONFIGURATION.....	3
2.2	PHYSICS PACKAGE.....	5
2.3	ELECTRONICS PACKAGE.....	5
2.3.1	PRINCIPAL FUNCTIONS OF THE ELECTRONIC CIRCUITS	5
3.	INSTALLATION AND OPERATION	8
3.1	INTRODUCTION	8
3.2	Safety!	8
3.3	Environmental Responsibility	8
3.4	SHIPPING AND RECEIVING INFORMATION	8
3.5	MOUNTING	9
3.6	PIN FUNCTION LAYOUT	11
3.7	NORMAL OPERATION	11
3.7.1	ANALOG FREQUENCY ADJUSTMENT	11
3.8	SERIAL INTERFACE OPERATION	11
3.8.1	INTRODUCTION.....	11
3.8.2	SERIAL INTERFACE CONNECTION	12
3.8.3	Standard RS-232 control & Monitoring commands	12
3.9	LOCK MONITOR and XTAL MONITOR OUTPUTS	13
3.9.1	TTL OR CMOS LEVEL 'LOCK MONITOR' GENERATION	13

1. INTRODUCTION

The Models STARLPRO-1500 /XX Rubidium Ultra-Stable Oscillators atomic resonance-controlled oscillators that provide an extremely stable frequency of 10 MHz (sinusoidal). The STARLPRO-1500 is designed for navigation , communication and timing instruments requiring such extremely stable and precise frequency .

This manual contains information about the operation and field maintenance of the STARLPRO-1500.

Chapter 2 contains a general description of the unit. It also presents a basic theory of operation for a technician or engineer who requires a better understanding of the unit's operation.

Chapter 3 gives information on how to install and operate the unit. It is recommended that these chapters be read prior to operate the unit. This chapter describes also the possible interface connection for the monitoring of the internal parameters and for the centre frequency adjustment.

2. STARLPRO-1500 SYSTEM DESCRIPTION

2.1 PRINCIPLE OF OPERATION AND BASIC CONFIGURATION

The STARLPRO-1500 essentially consists of a voltage-controlled crystal oscillator (VCXO) which is locked to a highly stable atomic transition in the ground state of the Rb87 isotope. While the frequency of the VCXO is at the convenient standard frequency of 10 MHz, the Rb clock frequency is at 6.834XXX GHz in the microwave range. The link between the two frequencies is done through a phase-stabilized frequency multiplication scheme whereby a synthesized frequency is admixed to enable exact matching.

The Rb atoms are confined in a vapor cell at an elevated temperature. The cell is placed in a microwave resonator to which the microwave power derived from the VCXO is coupled. The Rb87 atoms in the cell occur with equal probability in the two hyperfine energy levels of the ground state (F=1 and F=2).

In order to detect the clock transition between these two levels, the atoms need to be manipulated in such a way that most of them occur in only one level. This is done by optical pumping via a higher lying state (P). Fig. 2-1 visualizes the atomic energy levels and transitions involved in the optical pumping process.

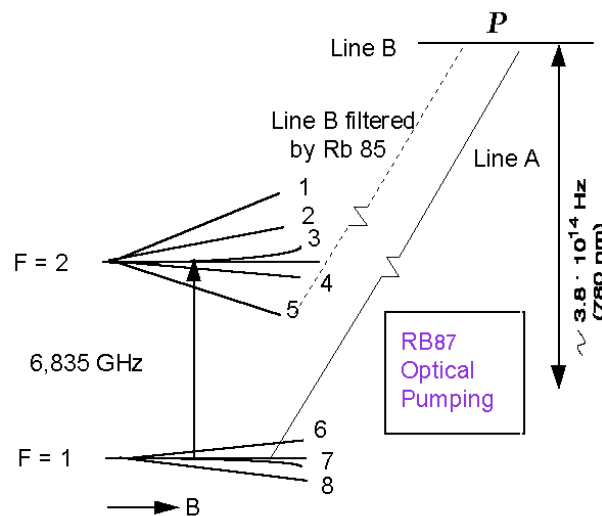

Fig. 2-1: Energy levels and transitions in Rb87 atoms during STARLPRO-1500 operation

The pump light comes from a Rb resonance lamp which emits the light of Rb87 atoms. This light, which intersects the absorption cell, is filtered in such a way that mainly one optical frequency, which corresponds to a transition out of one of the two ground state levels (line A), enters the principal absorption region.

The pump light excites Rb87 atoms which are in the lower hyperfine level ($F=1$) to the short-lived excited state P from which they decay to the two ground state levels ($F=1,2$) with equal probability. Since pumping occurs continuously out of the $F=1$ level, after some time, almost all atoms are found in the $F=2$ level and no further absorption occurs.

The transmitted light level is detected by a photodiode after the cell. If now a microwave field resonant with clock transition $F=2 @ F=1$ is coupled to the interaction region, the level $F=1$ is repopulated and light absorption is enhanced. A sweep of the microwave field over the resonance is detected as a small dip in the transmitted light level after the cell.

This signal is fed into a synchronous detector whose output generates an error signal which corrects the frequency of the VCXO when its multiplied frequency drifts off the atomic resonance maximum.

The absorption cell is filled with metallic vapor which contains Rb85 and Rb87 isotopes and a buffer gas. Filtering of the pump light is achieved in the entrance region of the cell by absorption with Rb85 atoms which have an accidental overlap with one of the Rb87 resonance transitions (line B): integrated filter cell.

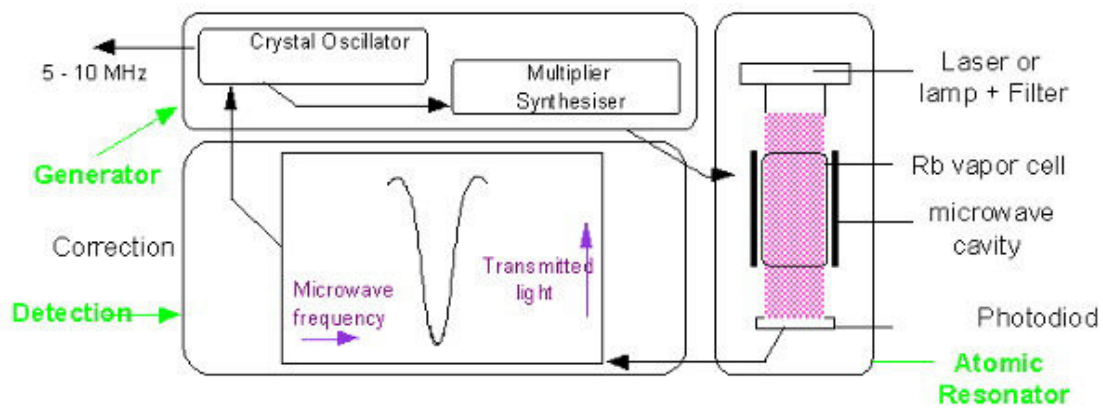

Fig. 2-2: Rubidium atomic clock principal block diagram

The principal function of the buffer gas is to keep the Rb atoms away from the cell walls and restrict their movements. As a result they are practically "frozen in place" for the interaction time with the microwave field. In this way the Doppler-effect is virtually removed and a narrow line width results.

The cell region is also surrounded by a so-called C-field coil which generates a small axial static magnetic field to resolve the Zeeman sub-transitions of the hyperfine line and select the clock transition, i.e. the one with the least magnetic sensitivity. To further reduce the magnetic sensitivity, the complete physics package is placed into nested magnetic shields.

Fig. 2-2 gives a basic overview of the different function blocks of the Rubidium atomic clock. The STARLPRO-1500 consists of three different packages. The optical elements, which include the Rb absorption cell and microwave cavity, form the atomic resonator, while the electronics package is constituted of the generator and the detection circuitry.

2.2 PHYSICS PACKAGE

The main design characteristics of the physics package are its low power consumption, small size and mass, along with minimal environmental sensitivities and mechanical ruggedness.

All parts of the physics package are incorporated in a aluminium tube surrounded by magnetic shields. Inside this tube, lamp and cell sections form two separate blocks which operate at well-defined but different temperatures. The cylindrical tube is filled with polyurethane foam for low thermal conductivity. The lamp and cell sections are separated with a glass window. This configuration greatly reduces the thermal flow between the blocks and the tube envelope. It allows a very compact design with low power consumption, short warm-up time and minimal environmental sensitivities.

Other design features which contribute to the compact design are:

- use of the integrated filter technique (IFT)
- use of a magnetron-type microwave resonator

The integrated filter technique which combines the optical filtering and pumping in one cell contributes also to the reliability since the configuration is simplified and the number of components reduced. The thermal capacitance of the cell assembly is relatively low. As a consequence, the necessary power during warm-up is greatly reduced.

The magnetron resonator is a cylindrical cavity loaded with a concentric capacitive-inductive structure (annular metal electrodes). It allows smaller cavity dimensions and concentrates the microwave field at the right region of the cell.

The Rb lamp is an electrode-less RF-discharge lamp: a heated glass bulb which contains Rb and a starter gas surrounded by an RF-coil.

Although the atomic clock transition frequency is inherently quite stable, there are second order influences which affect the frequency, i.e. temperature (buffer gas), light intensity (light shift = optical Stark effect), magnetic field (2nd order Zeeman effect). As a consequence, the temperatures of lamp and cell, the power of the lamp oscillator and the current in the C-field coil have to be carefully stabilized.

2.3 ELECTRONICS PACKAGE

2.3.1 PRINCIPAL FUNCTIONS OF THE ELECTRONIC CIRCUITS

The clock transition of a Rb resonator is a microwave transition at 6.834 .. GHz.

The microwave resonance occurs as a dip in the optical signal; i.e. in the Rb lamp light which, after transiting the cell, is detected by a photodiode.

The basic purpose of the electronics package is to synchronize the ingoing microwave frequency, derived from a quartz crystal oscillator, to this absorption dip. This is achieved by tuning the microwave frequency to maximum optical absorption.

Frequency variations of the microwave signal are transformed into DC current changes at the photodetector.

The dip, visualized in the photocurrent versus microwave frequency curve of Fig. 2-3, is very small: on the order of 1% of the total photocurrent which is however approximately 10 times higher compared to other commercial rubidium standards on the market.

Since DC detection of the dip is not feasible , an AC detection method is used for the following reasons:

- The dip amplitude is very small compared to the total photocurrent.

- The slope of the derivative of the dip photocurrent versus microwave frequency corresponds to roughly 1 nA/Hz. AC detection is the only solution to have a good signal/noise ratio since the photo-detector with associated amplifier are affected by flicker noise.

The AC method involves square wave frequency modulation of the microwave signal at a rate of $f_m \sim 330$ Hz. As shown in Figure 2-3 the modulated microwave frequency flips between 2 discrete frequency values f_1 et f_2 . The resulting photo- current $i(t)$ appears then also (after the transient) at 2 discrete values i_1 and i_2 .

The difference between i_1 and i_2 produces the error signal used for the quartz crystal center frequency adjustment until the mean value of f_1 and f_2 is exactly equal to the rubidium hyperfine frequency.

The clock microwave frequency of the Rb atoms in the vapor cell has a nominal value of 6834.684 MHz . This frequency is generated from a voltage controlled quartz oscillator (VCXO) which is multiplied up to 60 MHz .

Multiplication from 60 MHz to 6840 MHz is accomplished in one stage (x114) using a step-recovery diode mounted in the magnetron resonator inside the physics package.

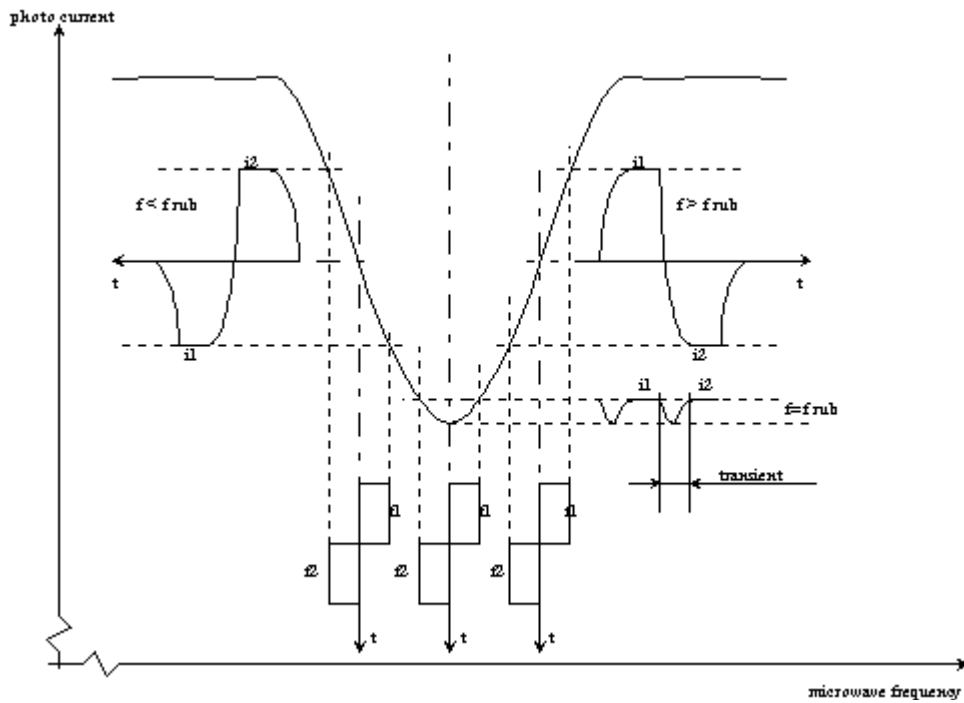

Fig. 2-3: Dip minimum detection

The 5.316... MHz phase modulation is introduced at the 60 MHz level. The 5.316... MHz spectrum is thus reproduced as a sideband of the 6840 MHz signal multiplied from the 10 MHz VCXO. The difference of the two frequencies corresponds to the Rb clock frequency.

This 5.316... MHz is generated by a synthesizer which is frequency modulated at the rate of f_m for dip detection.

The center frequency of the synthesizer is adjustable with step sizes of 5.12uHz in order to have the capability to adjust the STARLPRO-1500 output frequency (10 MHz) with a resolution of 5.12×10^{-13} per step and, also, to compensate the frequency shift due to the buffer gas pressure inaccuracies in the cell.

The Rb light is generated by a plasma discharge in the Rb lamp. This is sustained by an RF oscillator which drives a coil surrounding the Rb lamp bulb. In addition, the lamp is heated to 140°C and stabilized within 0.2°C over the full operating temperature range. The temperature-controlled heating power is generated by a wound resistive heater wire. Another part of the heating power is generated by the RF oscillator.

The Rb absorption cell is heated to ~85°C and also stabilized within 0.3°C over the full operating temperature range. The heating by a heater wire and the temperature control follows the same pattern as for the lamp heater.

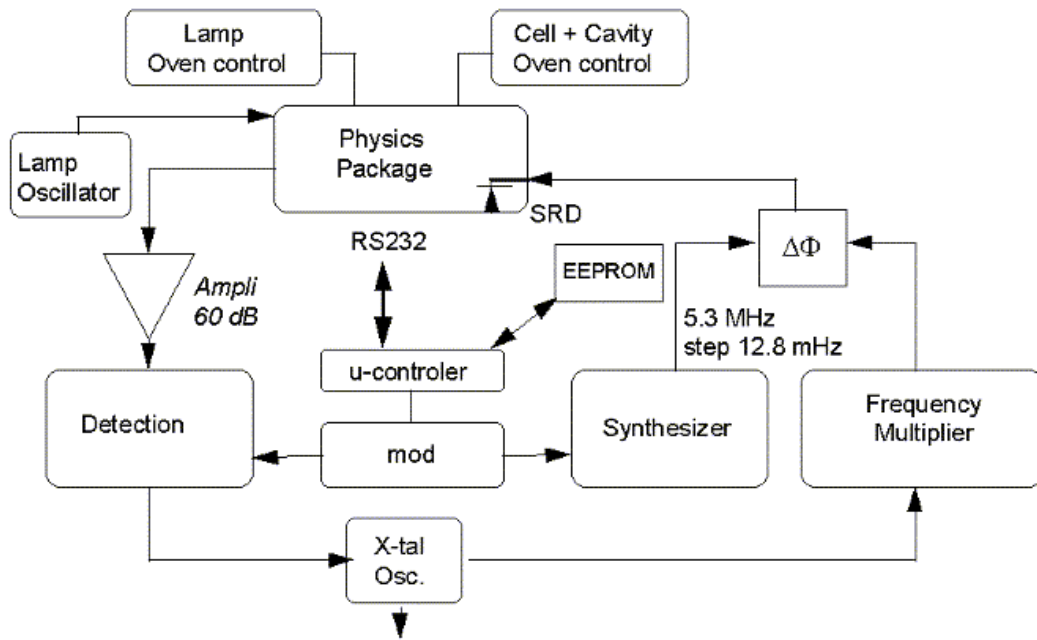

Fig. 2-4: STARLPRO-1500 block diagram

The C-field coil within the physics package generates a magnetic field necessary for Rb spectral lines separation. This magnetic field allows fine tuning of the 10MHz output frequency by shifting the Rb frequency hyperfine transition by the second-order Zeeman effect.

A high stability current generator drives this coil; it is adjustable by the user in order to attain a fine analog or numerical resolution via a digital-to-analog converter.

The user interface consists of the RS-232 port for the monitoring of the internal parameters and for the center frequency adjustment. In addition, an analog frequency control input is available to the user for center frequency adjustment by external potentiometer or external digital to analog converter.

The correct operation of the unit can be checked by a single open collector type output signal called 'lock monitor'. This lock monitor information is generated by the micro-controller and is a function of the following parameters:- Light level intensity

- Rb signal level (detected signal)
- Heaters supply voltages
- RF section health.

The different alarm threshold levels corresponding to the different internal STARLPRO-1500 electronics and physics parameters are programmed during the automatic adjustment procedure at the factory.

The power section of the STARLPRO-1500 consists of three dc-dc converters. One is used for generating the internal 5V needed by the logic circuitry, the two other converters are used for the lamp and the cell heaters.

The synchronization of the three converters is achieved by the use of a common ramp generator given by an internal 156.25 kHz signal derived by direct division of the 10 MHz main VCXO.

A detailed block diagram of the STARLPRO-1500 is given by Fig. 2-4.

3. INSTALLATION AND OPERATION

3.1 INTRODUCTION

This chapter of the manual contains information regarding the installation and operation of the SpT Model STARLPRO-1500. It is recommended to read this chapter carefully prior to operate the unit.

3.2 Safety!



- Use proper ESD precautions
- Ensure that all cables are properly connected

- The equipment contains small quantities of rubidium metal hermetically sealed inside the glass lamp and cell assemblies, hence, any dangers arising from ionizing radiation are caused for human health (exemption set in article 3 to Council directive 96/29/Euratom).
For further information, ask for the «*rubidium product data sheet*».
- Handling the product in a reasonably foreseeable conditions do not cause any risk for human health, exposure to the SVHC (substances of very high concern) would require grinding the component up.

3.3 Environmental Responsibility

- The equipment contains materials, which can be either re-used or recycled.
- Do not deposit the equipment as unsorted municipal waste. Leave it at an authorized local WEEE collection point or return to Orolia Switzerland SA to ensure proper disposal.
- To return the appliance :
 - a. Download and fill up the RMA form (from orolia.com) and send it to clocksupport@orolia.com
 - b. Once the RMA is approved, we will contact you with shipment process details.

3.4 SHIPPING AND RECEIVING INFORMATION

The STARLPRO-1500 is packaged and shipped in a foam-lined box. The unit is inspected mechanically and electrically prior to shipment. Upon receipt of the unit, a thorough inspection should be made to ensure that no damage has occurred during shipping. If any damage is discovered, please contact

Orolia Switzerland SA / Spectratime
 PHONE: +41 32 732 16 66
 FAX: +41 32 732 16 67
 CH-2000 NEUCHATEL / SWITZERLAND

Should it be necessary to ship the unit back, the original case and packing should be used. If the original case is not available, a suitable container with foam-packing is recommended.

CAUTION

Care must be taken for the transportation of the STARLPRO-1500 to ensure that the maximum acceleration due to a shocks 50g/ 11ms is not exceeded.

STARLPRO-1500 contains glass bulbs, crystal resonators and crystal filters.

When STARLPRO-1500 integrated into an instrument, such instrument shall be packed in a suitable container, similar to containers generally use for the transportation of instruments like scope, video display or computer.

3.5 MOUNTING

The unit should be mounted in preference to a metallic plate or metallic chassis. Mounting screws (6 x UNC-4-40) or (M3 with option code 'M3') , stainless steel 5mm maxi into the STARLPRO-1500 box) should be tightened with a torque between 50 Ncm and 100 Ncm.

The heat transfer characteristics of the mounting surface must be adequate to limit the rise of the unit's base plate to <+60°C. Since the minimum total power consumption for proper Rb operation is around 200mA / 24V, the allowable environmental temperature (T_{amax}), for this mounting is:

$$T_{amax} = 60^{\circ}\text{C} - V_s \times I_s \times R_k$$

CAUTION

Care must be taken to ensure that the maximum operating temperature is not exceeded, (+60°C as measured at the unit's base plate)

This maximum temperature can be reached when operating the unit into forced air flow at 60°C or by mounting the unit into user equipment with thermal interface corresponding to a thermal resistance of 1 to 2 °C/W between the STARLPRO-1500 unit and the ambient .

The STARLPRO-1500 is a well shielded unit, using several magnetic shield layers as well as special RF shields for the RF section. Nevertheless, some consideration must be given to the operating location of the unit, regardless of its application. To minimise frequency offsets and/or non-harmonic distortion, the unit should not be installed near equipment generating strong magnetic fields such as generators, transformers, etc.

The unit shall not be mounted within high sensitivity radio receiver without special provisions to prevent ratio interferences.

The general information for the mechanical interface of the STARLPRO-1500 unit is given in the package drawing of Fig. 4-4

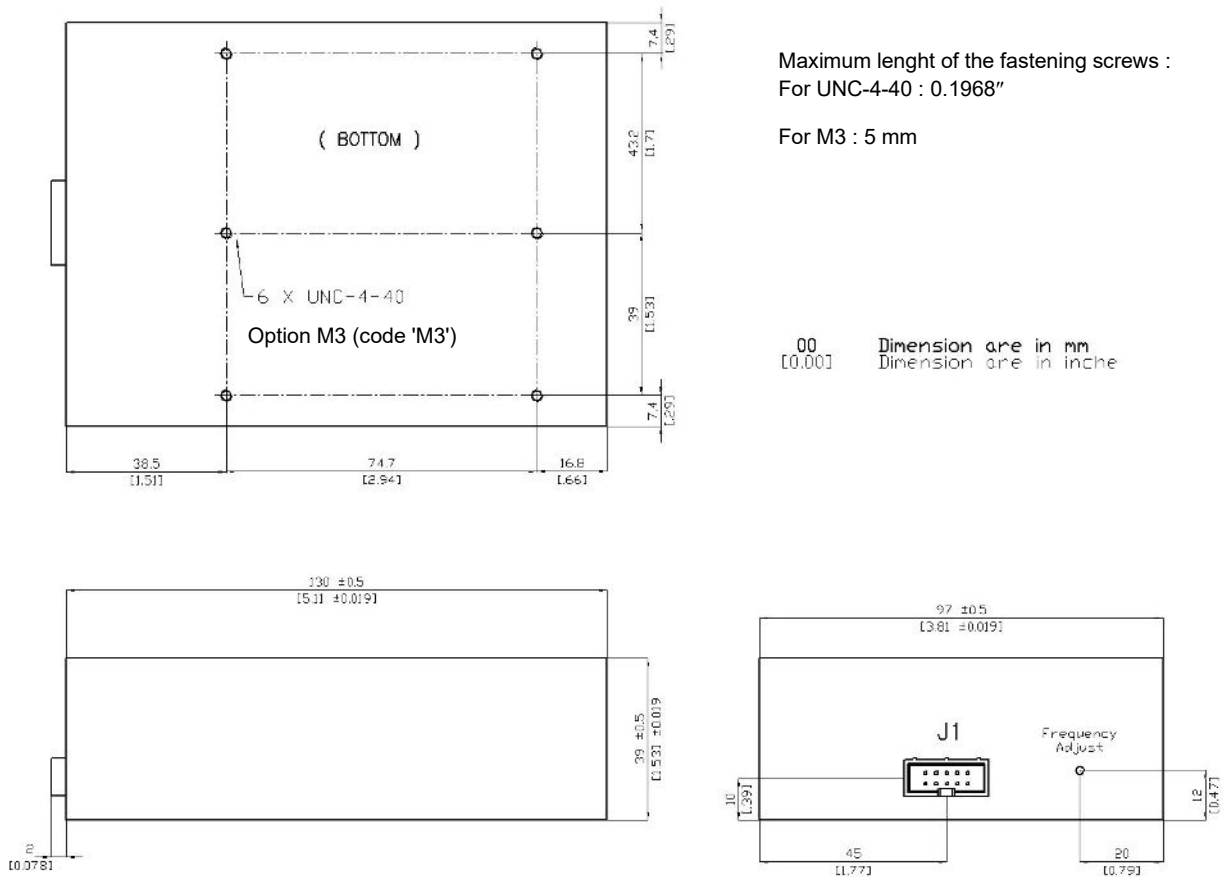

Fig. 4-4

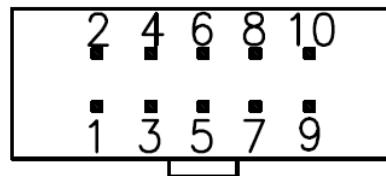

Fig. 4-5. Connector front view

3.6 PIN FUNCTION LAYOUT

The following table is providing the pin function description of the StarLPRO-1500 along with comparison with the LPRO from other vendors.

PIN FUNCTION LAYOUT						
LPFRS-01/LPRO TEMEX			LPRO DATUM			
Parameter	Requirements		Parameter	requirements		
Interface Circuits connector : (10 pin contact two rows)	Pin 1(output)	10 Mhz RF	Interface Circuits connector : (10 pin contact two rows)	Pin 1(output)	10 Mhz RF	Chassis ground
	Pin 2(output)	RF return		Pin 2(output)	RF return	
	Pin 3(RF return)	RF return Dc insulated		Pin 3(NA...)	Reserved Requires open in use	RF return-DC isolated
	Pin 4(output)	GND		Pin 4(output)	Chassis ground	
	Pin 5(RxD)	RxD (TTL) RS232 input (0-5V)		Pin 5(optional output)	Lamp voltage monitor (Acceptable level :3V to 13V after warm up)	
	Pin 6(output (with CMOS load))	Lock monitor * See Option Spec.		Pin 6(output (with CMOS load))	Lock monitor (Z=2K Ohm ±10%) 0V to 0.05V locked, 4.2V to 5.4V unlocked	
	Pin 7(input) V adjust	>1.5x10 ⁻² to 5V <-1.5x10 ⁻² to 0V		Pin 7(input)	>1.5x10 ⁻² to 5V <-1.5x10 ⁻² to 0V	
	Pin 8(GND)	GND		Pin 8(output)	Vin return	
	Pin 9(TxD)	TxD (TTL) RS232 output (0-5V)		Pin 9(optional output)	Xtal monitor Z=20K Ohm ±10%	
	Pin10(input) 24V/12V	24V (12V)		Pin10(input)	Vin power	

3.7 NORMAL OPERATION

When 12 Vdc (or 24V) is applied to pins 10 (+) and 4, 8 (-), the unit will immediately begin to generate a 10 MHz signal from the crystal oscillator. Within approximately 12 minutes (standard version) after application of input power the unit will "lock". Hence the crystal is now stabilised by the atomic resonant frequency.

The unit is able to provide a single signal called 'lock monitor' (pin 6) which toggles to high level when the internal crystal oscillator is locked to the Rb atomic resonance. (see chapter 4.7).

3.7.1 ANALOG FREQUENCY ADJUSTMENT

The STARLPRO-1500 is equipped with an analog frequency adjustment circuit which provides center frequency adjustment by applying an external voltage of 0 to 5V on Pin 7. Center frequency adjusted at factory is made by leaving this pin open using internal voltage reference of 2.5V ±5%. This means, applying 2.5V on this pin may induce a small frequency offset related to factory setting. To avoid such frequency offset, it is recommended to measure the voltage on the pin 7 first and then apply the same voltage value on the pin 7 to recover the exact voltage as applied for the factory setting. Furthermore, the StarLPRO offers adjustment capabilities using internal potentiometer adjustable with a small screwdriver to right side of connector (see drawing 4-4).

3.8 SERIAL INTERFACE OPERATION

3.8.1 INTRODUCTION

The STARLPRO-1500 is equipped with a microcomputer, associated with multi-channel D/A converters, used for setting its parameters. This microcomputer is also used for the interrogation and detection of the Rb absorption ' dip'.

The built-in serial interface allows an automatic parameter adjustment during the manufacturing process as well as coarse and fine adjustment of the centre frequency.

All the working parameters are stored in a built-in EEPROM memory. In addition an 8 channel A/D converter is used for monitoring the main internal signals such as: light level, signal level, thermostats heating currents etc...

3.8.2 SERIAL INTERFACE CONNECTION

The data transfer from the STARLPRO-1500 can be made by direct connection to a PC or standard terminal.

The data transfer parameters are the following:

bit rate: 9600 bits/s.

parity: none

start bit: 1

data bits: 8

stop bit: 1

IMPORTANT NOTE

In most cases, the serial PC interface accepts the 0 to 5V level and a direct connection can be made.

In case this 0 to 5V standard is not working , please refer to the small adaptation circuit called ' RS 232 adapter circuit' described in annex I.

3.8.3 Standard RS-232 control & Monitoring commands

The operating and monitoring parameters of the StarLPRO-1500 are accessible for read and write operations through the serial RS-232 port (9600 bits/sec., no parity, 1 start bit, 8 data bits, 1 stop bit).

There are 2 basics commands, which are $M, Cxxxx$

$M<CR><LF>$: monitors the basic internal signals of the atomic clock.

The returned answer looks like

$HH GG FF EE DD CC BB AA <CR> <LF>$

Where each returned byte is an ASCII coded hexadecimal value, separated by a <Space> character. All parameters are coded at full scale.

HH : Read-back of the user provided frequency adjustment voltage on pin 2 (0 to 5V)

GG : reserved

FF : peak voltage of Rb-signal (0 to 5V)

EE : DC-Voltage of the photocell (5V to 0V)

DD : varactor control voltage (0 to 5V)

CC : Rb-lamp heating current (Imax to 0)

BB : Rb-cell heating current (Imax to 0)

AA : reserved

Cxxx<CR><LF>: output frequency adjustment through the synthesizer, by steps of 5.12×10^{-13} , where xxx is a signed 16 bits word in hexa coded ASCII. This value is automatically stored in a EEPROM as last frequency which is applied after RESET or power-ON operation.

In Track mode this correction is not in use. The function FCsdddd do the same.

Set frequency adjustment	FCsdddd<CR><LF>	s=+/- signe dddd = limited within range : +32767/-32768 FC+99999 : interrogation	sdddd<CR><LF>	s: +/- signe dddd : frequ. Adj. in 5.12×10^{-13} step

3.9 LOCK MONITOR and XTAL MONITOR OUTPUTS

The STARLPRO-1500 contains a 'lock monitor' function which consist in a monitoring of the internal parameters like light level, Rb absorption 'dip' level, heaters monitoring etc.. and a comparison with nominal values. This principle of operation ensures the user that the STARLPRO-1500 VCXO is still locked correctly onto the Rb atoms resonance.

3.9.1 TTL OR CMOS LEVEL 'LOCK MONITOR' GENERATION

The lock monitor output can be directly connected to the CMOS load while protected with 1Kohm serial resistor. (Output impedance 1Kohm) .

Lock: < 0.5V (Logical '0') Unlock: > 4.2V (logical '1')

- End of document -