

# EK-5 Evaluation Kit

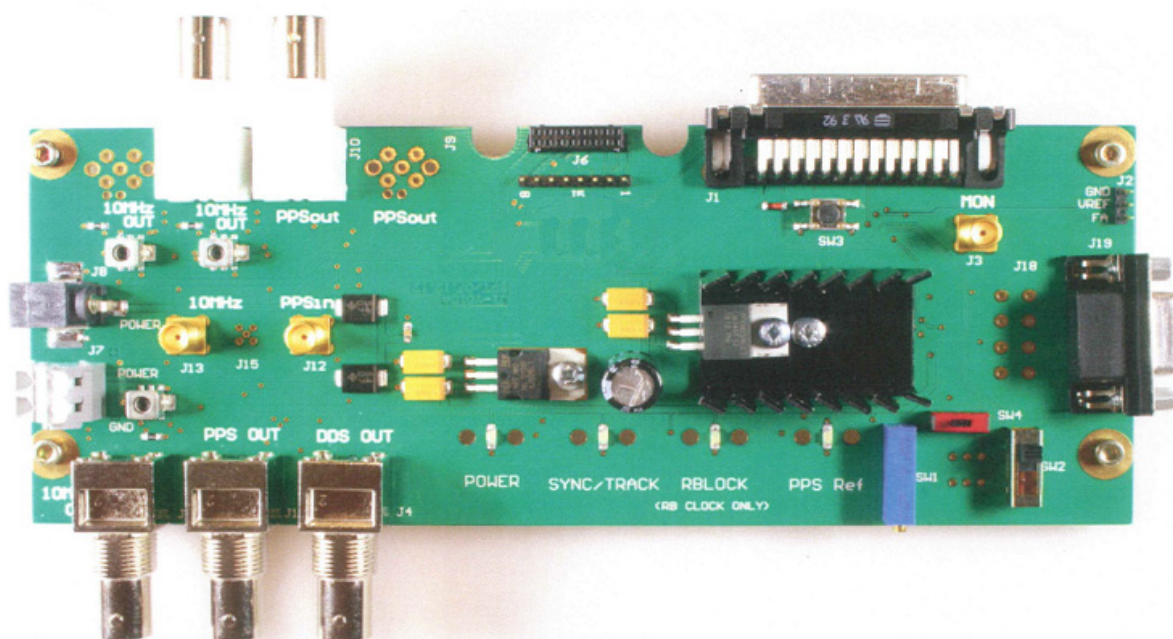

## User Manual

Document Part No: EK-5\_Evaluation\_Kit\_Manual

Revision: 051222

# Contents

1.	Board description.....	3
2.	LNRCLK-1500: ACTIVE CONNECTIONS.....	4
3.	LNRCLK-1500/GPS: ACTIVE CONNECTIONS .....	5
4.	GRCLK-1500: ACTIVE CONNECTIONS.....	6
5.	GRCLK-1500/GPS: ACTIVE CONNECTIONS .....	7
6.	GXCLK-500: ACTIVE CONNECTIONS.....	8
7.	Safety!.....	9
7.1	Environmental Responsibility .....	9

# 1. Board description

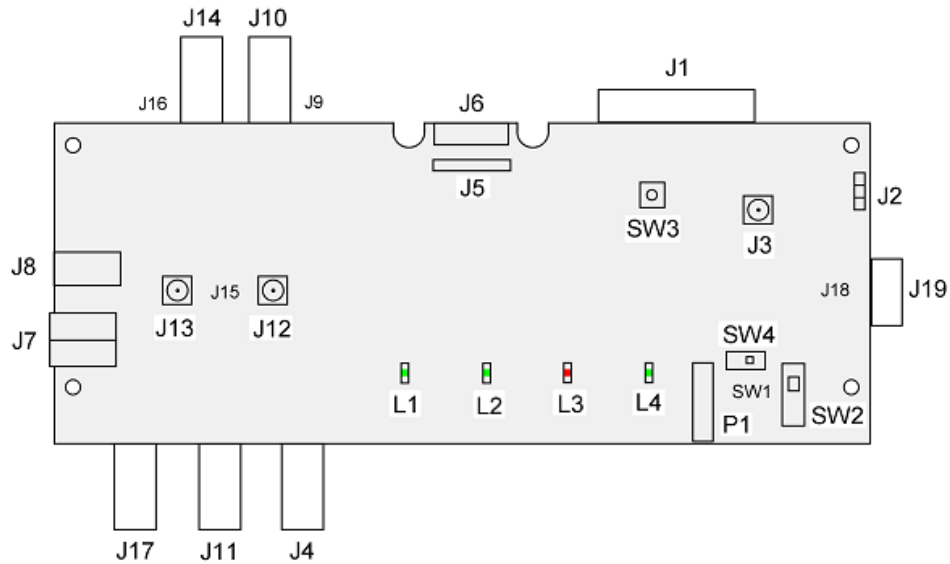
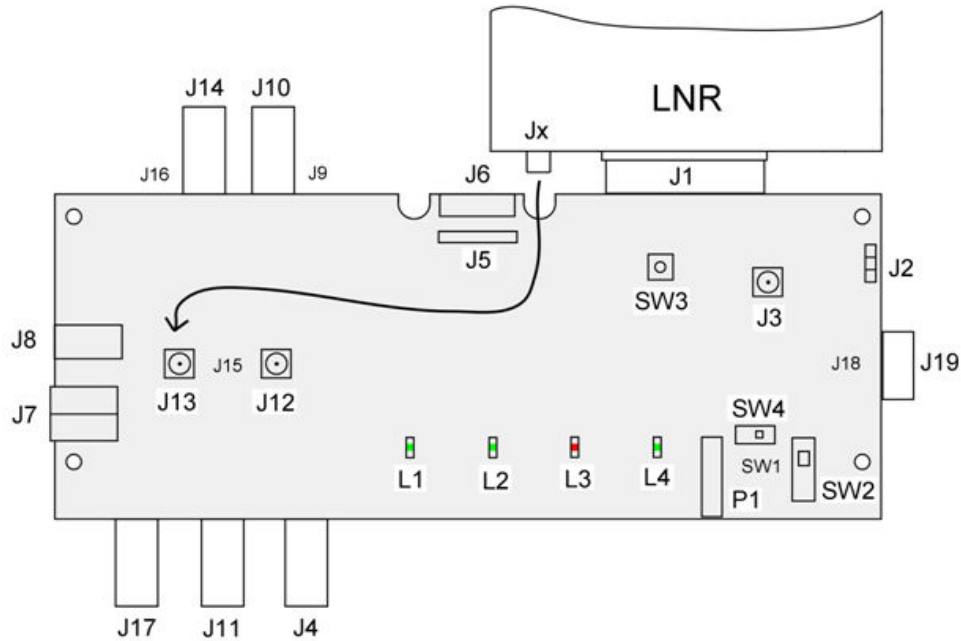

Figure 1

J1	Connector for LNR	
J2	External frequency adjust of the LNR. FA: connected to pin 6 of the LNR. Vref out: connected to pin 7. GND: ground. In association with switch SW4.	
J3	Internal use at SpT.	Not mounted.
J4	Output for Telecom Option 1 of the LNR.	
J5	LVDS Outputs for the GXClock-500. And 10MHz TTL.	
J6	Connector for GXClock-500.	
J7	Power supply. Pinch connector. GND: ground. Power: +12V or +24V for the LNR; 12V for the GXClock-500.	
J8	Power supply. Jack connector. GND: ground. Power: +12V or +24V for the LNR; 12V for the GXClock-500.	
J9	PPS Output; TTL level.	Not mounted.
J10	PPS Output; TTL level.	
J11	PPS Output; TTL level.	
J12	PPS Ref Input.	
J13	10MHz Input.	
J14	10MHz Output.	
J15	External 10MHz Input in case no LNR and no GXClock-500 are connected.	Not mounted.
J16	10MHz Output.	Not mounted.
J17	10MHz Output.	
J18	Second RS232 connector.	Not mounted.
J19	Serial RS232 interface; to connect the board to a PC with a strait cable.	
SW1	Working mode selector. Rotary switch.	Not mounted.
SW2	Working mode selector. Pos.top: Free run. Pos. Middle: Sync. Pos. Bottom: Track.	
SW3	Reset switch.	
SW4	External frequency adjust source. Left: potentiometer P1. Right: external, connector J2. Only for LNR. <b>Default: Right.</b>	
P1	Potentiometer for frequency tuning. In association with switch SW4. Only for LNR.	
L1	Green Led, power supply ok.	
L2	Green Led, tracking good.	
L3	Red Led, Rubidium line not locked.(LNR)	
L4	Green Led, PPS Ref tick.	

## 2. LNRCLK-1500: ACTIVE CONNECTIONS



Jx	10MHz SMA Output of the LNR	
J1	Connector for LNR	
J2	External frequency adjust of the LNR. FA: connected to pin 6 of the LNR. Vref out: connected to pin 7. GND: ground. In association with switch SW4.	
J4	Output for Telecom Option 1 of the LNR.	
J5	LVDS Outputs for the GXClock-500. And 10MHz TTL.	Not active.
J6	Connector for GXClock-500.	Some pins active.
J7	Power supply. Pinch connector. GND: ground. Power: +12V or +24V for the LNR; 12V for the GXClock-500.	
J8	Power supply. Jack connector. GND: ground. Power: +12V or +24V for the LNR; 12V for the GXClock-500.	
J10	PPS Output; TTL level.	
J11	PPS Output; TTL level.	
J12	PPS Ref Input.	
J13	10MHz Input.	
J14	10MHz Output.	Active if Jx to J13 cable.
J17	10MHz Output.	Active if Jx to J13 cable.
J19	Serial RS232 interface; to connect the board to a PC with a strait cable.	

SW2	Working mode selector. Pos.top: Free run. Pos. Middle: Sync. Pos. Bottom: Track.	
SW3	Reset switch.	
SW4	External frequency adjust source. Left: potentiometer P1. Right: external, connector J2. Only for LNR. <b>Default: Right.</b>	

P1	Potentiometer for frequency tuning. In association with switch SW4. Only for LNR.	
----	---	--

L1	Green Led, power supply ok.	
L2	Green Led, tracking good.	
L3	Red Led, Rubidium line not locked.(LNR)	
L4	Green Led, PPS Ref tick.	Active with J12.

### 3. LNRCLK-1500/GPS: ACTIVE CONNECTIONS

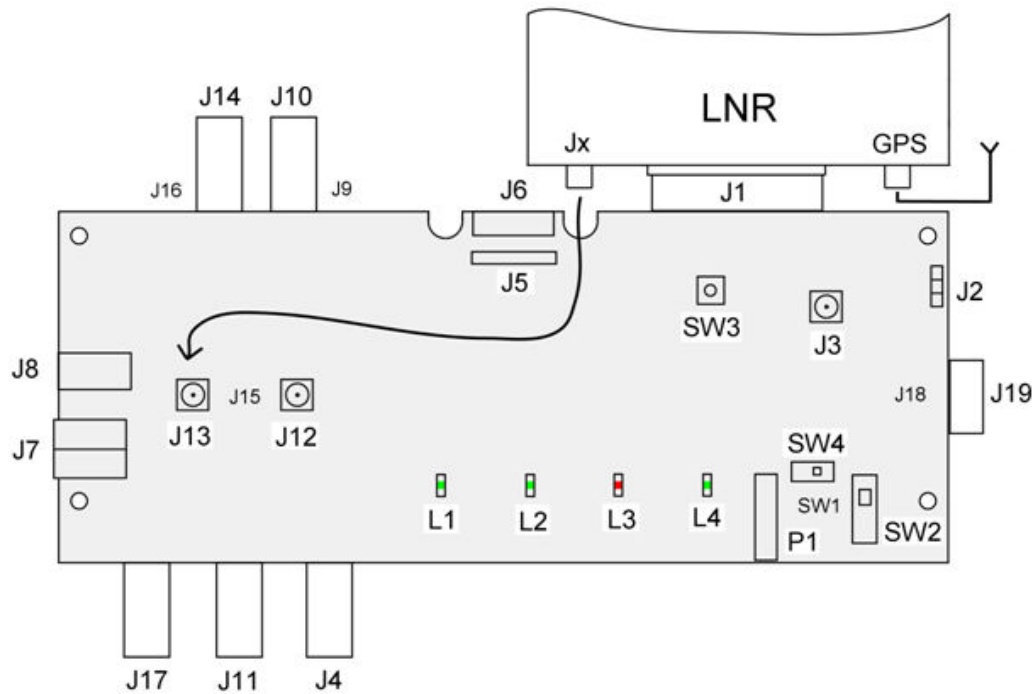

Jx	10MHz SMA Output of the LNR	
J1	Connector for LNR	
J2	External frequency adjust of the LNR. FA: connected to pin 6 of the LNR. Vref out: connected to pin 7. GND: ground. In association with switch SW4.	
J4	Output for Telecom Option 1 of the LNR.	
J5	LVDS Outputs for the GXClock-500. And 10MHz TTL.	Not active.
J6	Connector for GXClock-500.	Some pins active.
J7	Power supply. Pinch connector. GND: ground. Power: +12V or +24V for the LNR; 12V for the GXClock-500.	
J8	Power supply. Jack connector. GND: ground. Power: +12V or +24V for the LNR; 12V for the GXClock-500.	
J10	PPS Output; TTL level.	
J11	PPS Output; TTL level.	
J12	PPS Ref Input.	Not active.
J13	10MHz Input.	
J14	10MHz Output.	Active if Jx to J13 cable.
J17	10MHz Output.	Active if Jx to J13 cable.
J19	Serial RS232 interface; to connect the board to a PC with a strait cable.	
SW2	Working mode selector. Pos.top: Free run. Pos. Middle: Sync. Pos. Bottom: Track.	
SW3	Reset switch.	
SW4	External frequency adjust source. Left: potentiometer P1. Right: external, connector J2. Only for LNR. Default: Right.	
P1	Potentiometer for frequency tuning. In association with switch SW4. Only for LNR.	
L1	Green Led, power supply ok.	
L2	Green Led, tracking good.	
L3	Red Led, Rubidium line not locked.(LNR)	
L4	Green Led, PPS Ref tick.	Active with J12.

## 4. GRCLOCK-1500: ACTIVE CONNECTIONS

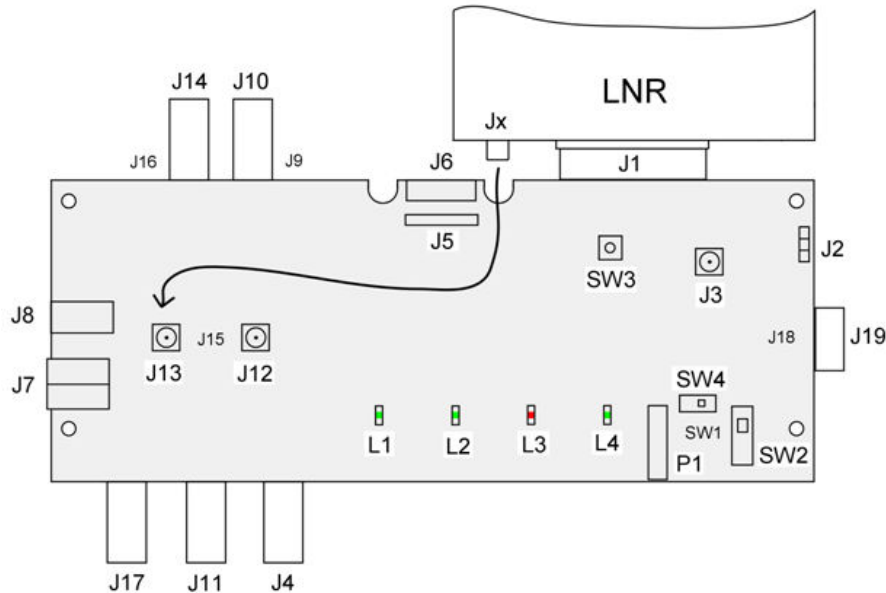

Jx	10MHz SMA Output of the LNR	
J1	Connector for LNR	
J2	External frequency adjust of the LNR. FA: connected to pin 6 of the LNR. Vref out: connected to pin 7. GND: ground. In association with switch SW4.	
J4	Output for Telecom Option 1 of the LNR.	
J5	LVDS Outputs for the GXClock-500. And 10MHz TTL.	10MHz on pin 1.
J6	Connector for GXClock-500.	Some pins active. 10MHz on pin 3.
J7	Power supply. Pinch connector. GND: ground. Power: +12V or +24V for the LNR; 12V for the GXClock-500.	
J8	Power supply. Jack connector. GND: ground. Power: +12V or +24V for the LNR; 12V for the GXClock-500.	
J10	PPS Output; TTL level.	
J11	PPS Output; TTL level.	
J12	PPS Ref Input.	
J13	10MHz Input.	
J14	10MHz Output.	Active if Jx to J13 cable.
J17	10MHz Output.	Active if Jx to J13 cable.
J19	Serial RS232 interface; to connect the board to a PC with a strait cable.	
SW2	Working mode selector. Pos.top: Free run. Pos. Middle: Sync. Pos. Bottom: Track.	
SW3	Reset switch.	
SW4	External frequency adjust source. Left: potentiometer P1. Right: external, connector J2. Only for LNR. <b>Default: Right.</b>	
P1	Potentiometer for frequency tuning. In association with switch SW4. Only for LNR.	
L1	Green Led, power supply ok.	
L2	Green Led, tracking good.	
L3	Red Led, Rubidium line not locked.(LNR)	
L4	Green Led, PPS Ref tick.	Active with J12.

## 5. GRCLOCK-1500/GPS: ACTIVE CONNECTIONS

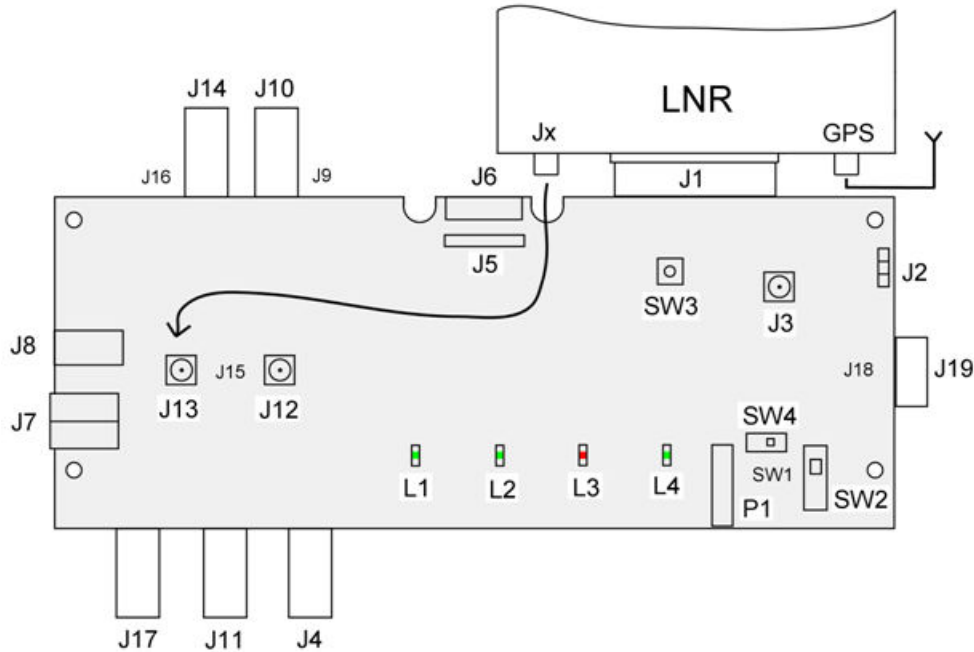

Jx	10MHz SMA Output of the LNR	
J1	Connector for LNR	
J2	External frequency adjust of the LNR. FA: connected to pin 6 of the LNR. Vref out: connected to pin 7. GND: ground. In association with switch SW4.	
J4	Output for Telecom Option 1 of the LNR.	
J5	LVDS Outputs for the GXClock-500. And 10MHz TTL.	10MHz on pin 1.
J6	Connector for GXClock-500.	Some pins active. 10MHz on pin 3.
J7	Power supply. Pinch connector. GND: ground. Power: +12V or +24V for the LNR; 12V for the GXClock-500.	
J8	Power supply. Jack connector. GND: ground. Power: +12V or +24V for the LNR; 12V for the GXClock-500.	
J10	PPS Output; TTL level.	
J11	PPS Output; TTL level.	
J12	PPS Ref Input.	Not active.
J13	10MHz Input.	
J14	10MHz Output.	Active if Jx to J13 cable.
J17	10MHz Output.	Active if Jx to J13 cable.
J19	Serial RS232 interface; to connect the board to a PC with a strait cable.	
SW2	Working mode selector. Pos.top: Free run. Pos. Middle: Sync. Pos. Bottom: Track.	
SW3	Reset switch.	
SW4	External frequency adjust source. Left: potentiometer P1. Right: external, connector J2. Only for LNR. <b>Default: Right.</b>	
P1	Potentiometer for frequency tuning. In association with switch SW4. Only for LNR.	
L1	Green Led, power supply ok.	
L2	Green Led, tracking good.	
L3	Red Led, Rubidium line not locked.(LNR)	
L4	Green Led, PPS Ref tick.	Active with J12.

## 6. GXCLOCK-500: ACTIVE CONNECTIONS

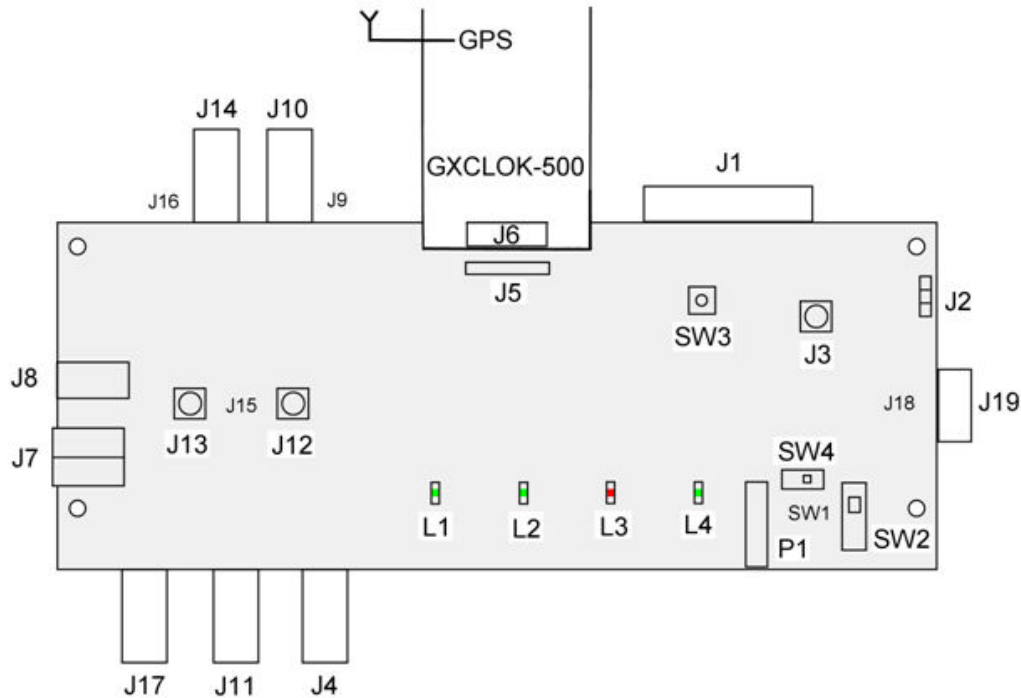

<b>J1</b>	Connector for LNR	Some pins active. 10MHz on pin 24 PPS on pin 20.
<b>J2</b>	External frequency adjust of the LNR. FA: connected to pin 6 of the LNR. Vref out: connected to pin 7. GND: ground. In association with switch SW4.	Not active.
<b>J4</b>	Output for Telecom Option 1 of the LNR.	Not active.
<b>J5</b>	LVDS Outputs for the GXClock-500. And 10MHz TTL.	
<b>J6</b>	Connector for GXClock-500.	
<b>J7</b>	Power supply. Pinch connector. GND: ground. Power: +12V or +24V for the LNR; 12V for the GXClock-500.	
<b>J8</b>	Power supply. Jack connector. GND: ground. Power: +12V or +24V for the LNR; 12V for the GXClock-500.	
<b>J10</b>	PPS Output; TTL level.	
<b>J11</b>	PPS Output; TTL level.	
<b>J12</b>	PPS Ref Input.	Activation by software.
<b>J13</b>	10MHz Input.	
<b>J14</b>	10MHz Output.	Not active. Active with J13.
<b>J17</b>	10MHz Output.	Not active. Active with J13.
<b>J19</b>	Serial RS232 interface; to connect the board to a PC with a strait cable.	
<b>SW2</b>	Working mode selector. Pos.top: Free run. Pos. Middle: Sync. Pos. Bottom: Track.	Not active.
<b>SW3</b>	Reset switch.	Not active.
<b>SW4</b>	External frequency adjust source. Left: potentiometer P1. Right: external, connector J2. Only for LNR. <b>Default: Right.</b>	Not active.
<b>P1</b>	Potentiometer for frequency tuning. In association with switch SW4. Only for LNR.	Not active.
<b>L1</b>	Green Led, power supply ok.	
<b>L2</b>	Green Led, tracking good.	
<b>L3</b>	Red Led, Rubidium line not locked.(LNR)	Not active.
<b>L4</b>	Green Led, PPS Ref tick.	Active with J12.



## 7. Safety!



- Use proper ESD precautions
- Ensure that all cables are properly connected

- Handling the product in a reasonably foreseeable conditions do not cause any risk for human health, exposure to the SVHC (substances of very high concern) would require grinding the component up.

### 7.1 Environmental Responsibility

- The equipment contains materials, which can be either re-used or recycled.
- Do not deposit the equipment as unsorted municipal waste. Leave it at an authorized local WEEE collection point or return to Orolia Switzerland SA to ensure proper disposal.
- To return the appliance:
  - Download and fill up the RMA form (from [www.orolia.com/warranty-information/](http://www.orolia.com/warranty-information/)) and send it to [clocksupport@orolia.com](mailto:clocksupport@orolia.com). We will contact you with shipment process details.

- End of document -