

MINIRAFS RB ATOMIC FREQUENCY STANDARD

ULTRA-HIGH PERFORMANCE,
MINIATURIZED, SPACE-QUALIFIED.



The MiniRAFS is a cost-effective, ultra-high performance, miniaturized, space-qualified rubidium frequency standard.

It's designed with the latest technologies, providing advanced features, such as long lifetime, high reliability, ultra lightweight and ultra low phase noise, for next-generation space applications.

Key Features

- Low temperature sensitivity
- Good short term stability
- Small volume
- Excellent long term stability
- Rb lamp extended life expectancy (>20 years)

Main Applications

- Space scientific missions
- Secure satellite communications
- Tracking and guidance control
- Advanced low satellite orbit digital communications

Safran Electronics & Defense is with you every step of the way, building in the intelligence that gives you a critical advantage in observation, decision-making and guidance.

Key Product Spec

- Volume 0.39 liters
- Thermal sensitivity over -20°C to 60°C $< 37 \times 10^{-13} / ^\circ\text{C}$
- Stability $< 2 \times 10^{-13} / 1000\text{sec}$
- Long term stability $< 3 \times 10^{-11} / \text{month} / < 1 \times 10^{-9}$ over 10 years
- Power supply with DC-DC optional conv. compatible with 28V or 50V power bus
- Output frequency 10MHz

Package

(all dimensions in millimeters)

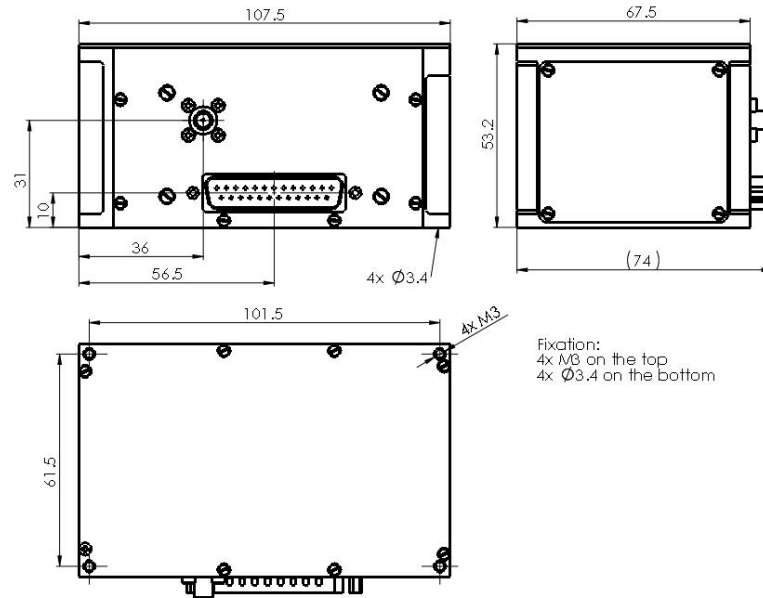

Pin functions & layout (J2: 25 pins D_SUB)

N°	I/O	Designation	Description
1	O	10MHz	10MHz sine output (0dBm / 50Ω)
2	I/O	GND	Power return
3	O	SYNCH+	150KHz (duty cycle of 50%) derived from 60MHz main output frequency (frequency divider of 480).(used with DC-DC stackable converter)
4	O	SYNCH-	Inverse of SYNCH+
5	I/O	GND	Power return
6	O	LOCK	Lock indicator
7	O	RB_SIGNAL	Atomic signal level monitoring (0 to 5V range)
8	I	T_LAMP_ADJ	This pin shall be Not Connected (NC) for operation under vacuum. Under air condition, this pin shall be connected to GND (pin 9).
9	I/O	GND	Power return
10	O	VREF	+5V reference (Imax=1mA, 4.95 to 5.05V range)
11	I/O	GND	Power return
12	I	VAD	+16V input voltage (15.5 to 16.5V range)
13	I	VDD	+3.5V input voltage (3.5 to 5V range)
14	I/O	GND	Power return
15	I/O	GND	Power return
16	I	GND	Power return
17	I	GND	Power return
18	O	HEAT_CELL	Level of the heater control for the cell (0 to 5V range)
19	O	HEAT_LAMP	Level of the heater control for the lamp (0 to 5V range)
20	O	RB_LIGHT	Light level intensity monitoring (0 to 5V range)
21	O	VC_MON	Voltage control of VCXO (0 to 5V range)
22	I	FREQ_ADJ	Analogue frequency adjustment (0 to 5V range)
23	I/O	GND	Power return
24	I	VAD	+16V input voltage (15.5 to 16.5V range)
25	I/O	GND	Power return

Technical Specifications

Parameter	value	Unit
PERFORMANCE METRICS		
Frequency		
Main (Sinus on SMA connector)	60.00	MHz
Auxiliary (sinus wave)	10.00	MHz
Frequency accuracy		
after launch & commissioning phase :	$\leq 2 \times 10^{-10}$	
Under vacuum conditions at delivery	$\leq 1 \times 10^{-10}$	
Freq. Stab Short Term (max)		
1 sec	1×10^{-11}	
10 sec	3×10^{-12}	
100 sec	1×10^{-12}	
1000 sec	3×10^{-13}	
10000 sec (drift removed)	1×10^{-13}	
flicker floor (drift removed)	2×10^{-13}	
Freq. Stab Long Term (typical)	$< 1 \times 10^{-10}$	Per year
Outputs 60MHz Signal Level	7 ± 1	dBm
Auxiliary 10MHz	0 ± 1	dBm
Return loss power ON conditions (nominal output impedance 50 Ω)/60MHz	> 20	dB
Spurious Signals (60MHz)	< -80	dB
(band +/- 2MHz)		dB
Outside	< -60	
Harmonics	< -30	dBc
Phase Noise (60 MHz)		
1Hz	-64	dBc
10 Hz	-84	dBc
100 Hz	-129	dBc
1000 Hz	-134	dBc
10000 Hz	-135	dBc
100000 Hz	-135	dBc
PHYSICAL		
Envelope and dimensions	L=107.5 W=67.5 H=53.5	mm mm mm
Mass	0.45	Kg
Stiffness	> 100	Hz
Design Lifetime	> 20	Years
ELECTRICAL INTERFACES		
ELECTRICAL POWER		
Digital power voltage range	3.5 to 5	V
Current	< 0.2	A
Analog power voltage range	15.5 to 16.5	V
Current	< 0.6	A
TM		
TM List		
Lock Indication	Open collector	V
Rb Light	0-5	V
Rb Signal	5-0	V
VCXO control	0-5	V
Rb Cell heater control	0-5	V
Rb Lamp Heater control	0-5	V

STRUCTURAL & MECHANICAL INTERFACES			
Surface Finish-Flatness			
Overall contact area	< 0.2		mm
Local flatness	$< 0.1/100$		mm/mm
Roughness	< 3.2		μm
Interconnections			
RF outputs	SMA (J01) SUB-D		
TM & Power	25 (J02)		
ENVIRONMENTAL & THERMAL INTERFACES			
Interface Heat Flux	< 0.3		W/cm ²
Power dissipation			
During warm-up	< 15		W
During nominal operation	< 10		W
Temperature limits (under vac conditions)			
Operating	-15 to +55		°C
Short-term variation	$\leq \pm 1$		°C
Acceptance	-20 to +60		°C
Qualification	-25 to + 65		°C
Cold start	-25		°C
Non-operating	-55 to + 85		°C
Vacuum level	10^{-5}		mbar
Magnetic field	$< \pm 1$		Gauss
Radiation Environment.	LEO/MEO/GEO orbits		
ORBITAL LIFETIME & MTBF			
Reliability figure (LEO,MEO)	< 1000		FIT
Design Lifetime	> 20		Years

miniRAFS Description

The miniature Rubidium Atomic Frequency Standard (miniRAFS) is a state-of-the-art ultra-stable atomic clock able to deliver a frequency accuracy better than $1E-9$ over 10 years operations in orbit along with very good short and mid-term frequency stability.

The miniRAFS unit is a complete atomic clock within very small volume. It can be complemented on request with an Electronic Power Conditioning name "EPC" which includes the DC/DC converter and the electrical interface to the satellite.

The EPC design could be adapted for specific satellite requirements.

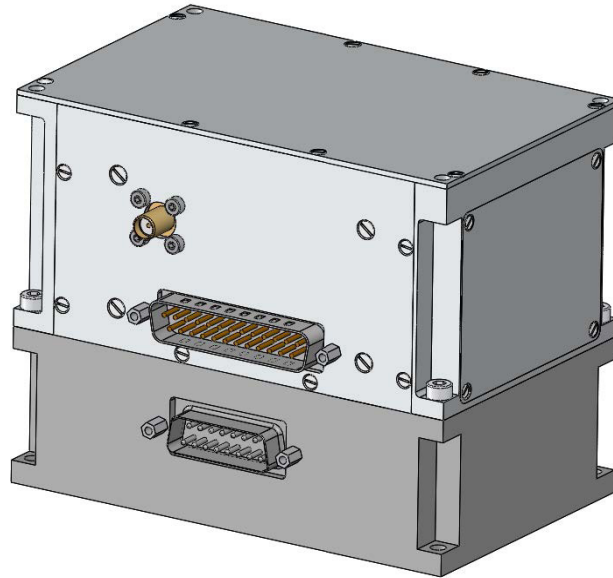
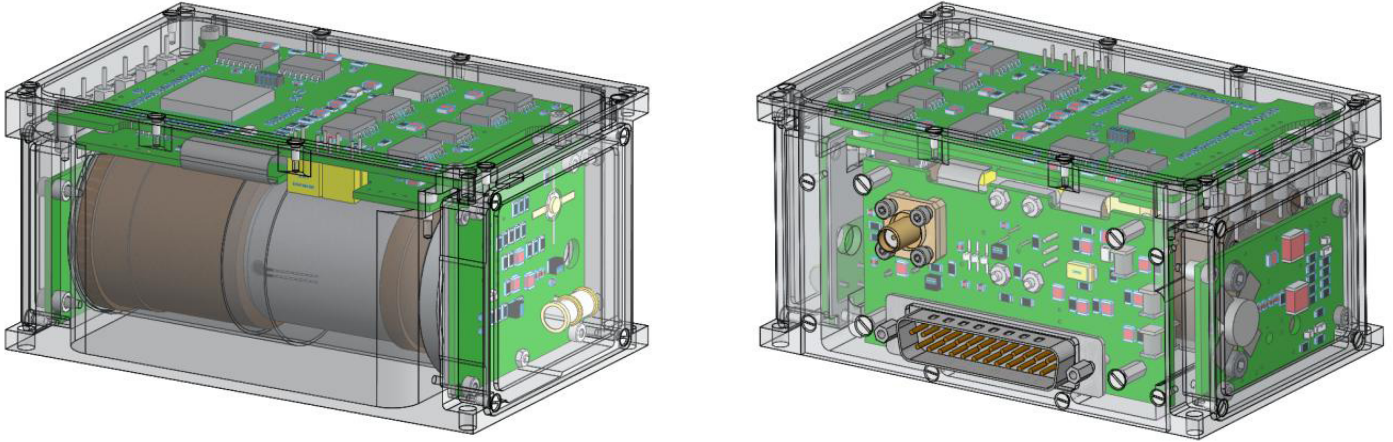

miniRAFS with OPTIONAL EPC module

miniRAFS General Function & Block Diagram

The miniRAFS is a complete Rb clock module. The Rb clock essentially consists of a voltage-controlled crystal oscillator (VCXO) which is locked to a highly stable atomic transition in the ground state of the Rb87 isotope. While the frequency of the VCXO is at the convenient standard frequency of 10 MHz, the Rb clock frequency is at 6.834 GHz in the microwave range. The link between the two frequencies is done through a phase-stabilized frequency multiplication scheme whereby a synthesized frequency is admixed to enable exact matching.

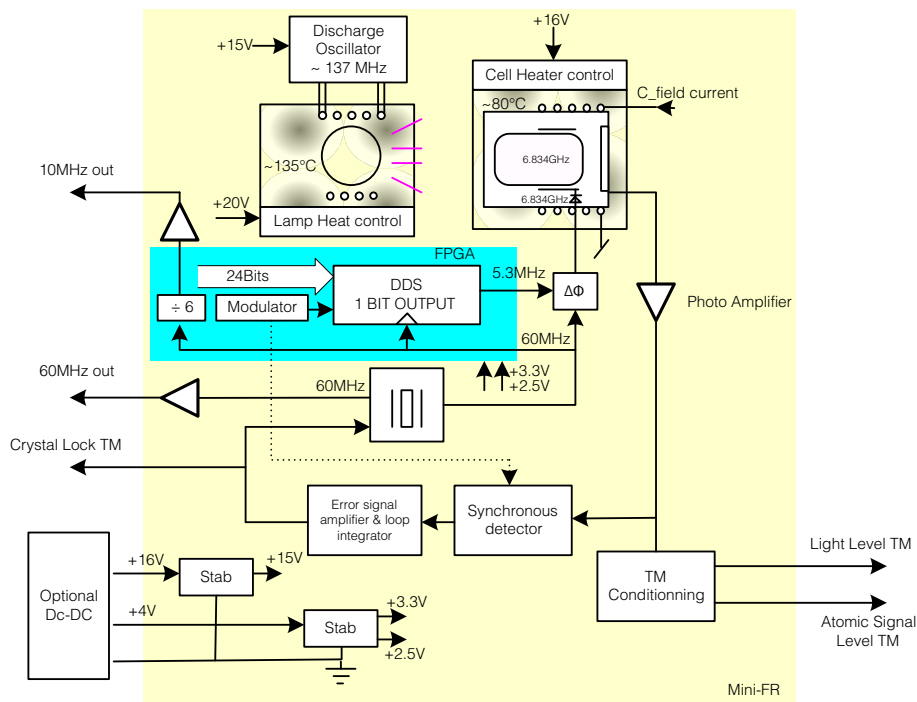

miniRAFS Functional Block Diagram

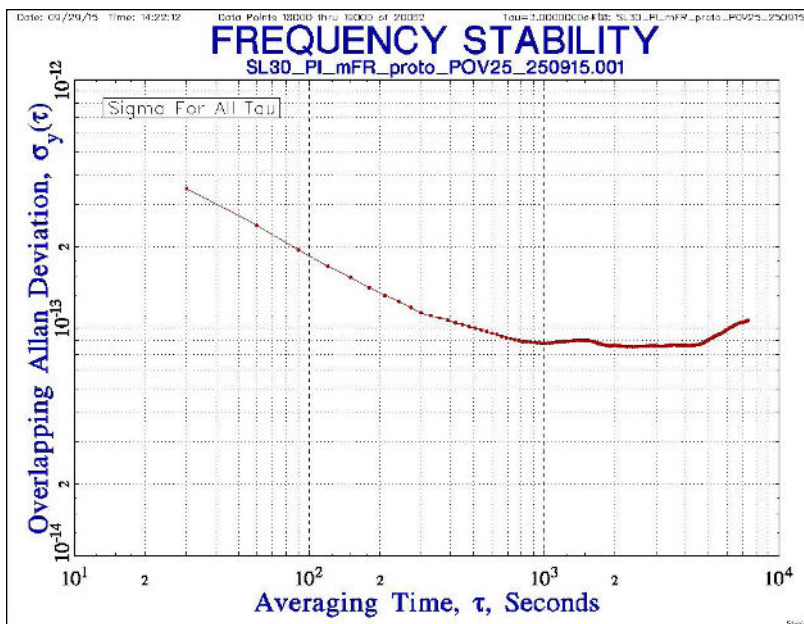

miniRAFS Typical Short Term Stability Performance

**POWERED
BY TRUST**



Safran Electronics & Defense
safran-electronics-defense.com

