

TS1000T – Datasheet

Single axis analog accelerometer

The TS1000T accelerometer is the best in class high temperature MEMS Accelerometer specifically designed for inertial directional drilling applications. It offers the highest performance stability with shock resistance, as well as the lowest non-linearity and noise in the marketplace for MEMS.

The proven MEMS technology by Safran Sensing Technologies Switzerland is pushing forward the vibration and shock endurance in temperature. Each product is systematically fully tested in production over the whole temperature range. The internal signal analog conditioning offers a built in Self-Test and overload functions for your confidence at all time



Key features (±2g range)

- **High temperature range:** -40°C to 175°C
- **Long term Bias Repeatability** ±2mg
- **Non-linearity:** <0.3% of full scale
- **Excellent Bias Residual model** < ±0.6 mg
- **SWaP¹** : 9x9x3.5mm³ - 1.5gr - 10mW
- **Robust to repetitive shocks**

Key Parameters, typical values	TS1002T	TS1005T	TS1010T	Unit
Full-scale acceleration	± 2	± 5	± 10	g
Residual Bias modeling error ²	0.6	1.5	3.0	mg
Long-term Bias repeatability ³	2	5	10	mg
Residual Scale factor modeling error ²	300	300	300	ppm
Noise in band	7	17	34	µg/√Hz
Non Linearity (IEEE norm)	0.3	0.3	0.3	% FS
Endurance shock (500 times)	1500	1500	1500	g

¹: SWaP: Size Weight and Power

²: Using 3rd order polynomial compensation

³: See Glossary

Featured Applications (non-exhaustive)

- **Measurement While Drilling (MWD)**
- **Logging While Drilling (LWD)**
- **Rotary Steerable Systems (RSS)**
- **Geothermal drilling**
- **Borehole Survey**
- **Geological Exploration**

TS1002T PARAMETERS

All values are specified at ambient temperature (20°C) and at 3.3 V supply voltage V_{DD} , unless otherwise stated. Acceleration values are defined for differential signal (OUTP-OUTN).

Parameter	Comments	Min	Typ.	Max	Unit
Accelerometer					
Full scale		±2			g
Non-Linearity	IEEE Norm , % of full scale		0.3	1.0	%
Non-Linearity	Under vibration, % of full scale		0.1	0.3	%
Frequency response	±3dB	100			Hz
Resonant frequency	Overdamped		1.4		kHz
Noise	in band		7		µg/√Hz
Resolution	@ 1Hz		7		µg rms
Startup time	Sensor operational, delay once POR triggered		40		µs
Bias (K0)					
Nominal	Calibration accuracy	-7		7	mg
Temperature coefficient	Measured over [-40°C , 150°C]		150		µg/°C
In-run bias stability	Based on Allan Variance characterization (@ 10s)		4		µg
Long-term repeatability	See glossary		2		mg
Initial residual Modeling error	3 rd order temperature compensation [-40°C , 150°C]		0.6		mg
Scale factor (K1)					
Nominal	Calibration accuracy	1.33	1.35	1.37	V/g
Temperature coefficient	Measured over [-40°C , 150°C]	20	120	220	ppm/°C
Long-term repeatability	See glossary		1000		ppm
Initial residual Modeling error	3 rd order temperature compensation [-40°C , 150°C]		300		ppm
Axis misalignment					
Nominal		-10		10	mrad
Lifespan					
Usable life expectancy	@150 °C	1000			hours
	@175 °C		50		hours
Self-test					
Frequency	Square wave output	22	24.4	26.8	Hz
Duty cycle			50		%
Amplitude	Peak to peak		1.3		g
Input threshold voltage	active high	80			% V_{DD}
Temperature sensor					
Output voltage @20°C		1.20	1.23	1.26	V
Sensitivity			-4.0		mV/°C
Output current load				10	µA
Output capacitive load				10	pF
Reset					
Input threshold voltage	active low			20	% V_{DD}
Power requirements					
Supply voltage (V_{DD})		3.2	3.3	3.4	V
Supply current (I_{DD})			3	4	mA
Accelerometer outputs					
Output voltages	OutP, OutN over full scale	0.14		3.16	V
Differential output	Over full scale		±2.7		V
Resistive load		1000			kΩ
Capacitive load				100	pF

Table 1: TS1002T Specifications
TS1005T PARAMETERS

All values are specified at ambient temperature (20°C) and at 3.3 V supply voltage V_{DD}, unless otherwise stated. Acceleration values are defined for differential signal (OUTP-OUTN).

Parameter	Comments	Min	Typ.	Max	Unit
Accelerometer					
Full scale		±5			g
Non-Linearity	IEEE, % of full scale		0.3	1.0	%
Non-Linearity	Under vibration, % of full scale		0.1	0.3	%
Frequency response	±3dB	100			Hz
Resonant frequency	Overdamped		2.9		kHz
Noise	in band		17		µg/√Hz
Resolution	@ 1Hz		17		µg rms
Startup time	Sensor operational, delay once POR triggered		40		µs
Bias (K0)					
Nominal	Calibration accuracy	-17		17	mg
Temperature coefficient	Measured over [-40°C , 150°C]		375		µg/°C
In-run bias stability	Based on Allan Variance characterization (@ 10s)		10		µg
Long-term repeatability	See glossary		5		mg
Initial residual Modeling error	3 rd order temperature compensation [-40°C , 150°C]		1.5		mg
Scale factor (K1)					
Nominal	Calibration accuracy	532	540	548	mV/g
Temperature coefficient	Measured over [-40°C , 150°C]	20	120	220	ppm/°C
Long-term repeatability	See glossary		1000		ppm
Initial residual Modeling error	3 rd order temperature compensation [-40°C , 150°C]		300		ppm
Axis misalignment					
Nominal		-10		10	mrad
Lifespan					
Usable life expectancy	@150 °C	1000			hours
	@175 °C		50		hours
Self-test					
Frequency	Square wave output	22	24.4	26.8	Hz
Duty cycle			50		%
Amplitude	Peak to peak		1.3		g
Input threshold voltage	active high	80			% V _{DD}
Temperature sensor					
Output voltage @20°C		1.20	1.23	1.26	V
Sensitivity			-4.0		mV/°C
Output current load				10	µA
Output capacitive load				10	pF
Reset					
Input threshold voltage	active low			20	% V _{DD}
Power requirements					
Supply voltage (V _{DD})		3.2	3.3	3.4	V
Supply current (I _{DD})			3	4	mA
Accelerometer outputs					
Output voltages	OutP, OutN over full scale	0.14		3.16	V
Differential output	Over full scale		±2.7		V
Resistive load		1000			kΩ
Capacitive load				100	pF

Table 2: TS1005T Specifications

TS1010T PARAMETERS

All values are specified at ambient temperature (20°C) and at 3.3 V supply voltage V_{DD} , unless otherwise stated. Acceleration values are defined for differential signal (OUTP-OUTN).

Parameter	Comments	Min	Typ.	Max	Unit
Accelerometer					
Full scale		±10			g
Non-Linearity	IEEE, % of full scale		0.3	1.0	%
Non-Linearity	Under vibration, % of full scale		0.1	0.3	%
Frequency response	±3dB	100			Hz
Resonant frequency	Overdamped		3.7		kHz
Noise	in band		34		µg/√Hz
Resolution	@ 1Hz		34		µg rms
Startup time	Sensor operational, delay once POR triggered		40		µs
Bias (K0)					
Nominal	Calibration accuracy	-34		34	mg
Temperature coefficient	Measured over [-40°C , 150°C]		750		µg/°C
In-run bias stability	Based on Allan Variance characterization (@ 10s)		20		µg
Long-term repeatability	See glossary		10		mg
Initial residual Modeling error	3 rd order temperature compensation [-40°C , 150°C]		3.0		mg
Scale factor (K1)					
Nominal	Calibration accuracy	266	270	274	mV/g
Temperature coefficient	Measured over [-40°C , 150°C]	20	120	220	ppm/°C
Long-term repeatability	See glossary		1000		ppm
Initial residual Modeling error	3 rd order temperature compensation [-40°C , 150°C]		300		ppm
Axis misalignment					
Nominal		-10		10	mrad
Lifespan					
Usable life expectancy	@150 °C	1000			hours
	@175 °C		50		hours
Self-test					
Frequency	Square wave output	22	24.4	26.8	Hz
Duty cycle			50		%
Amplitude	Peak to peak		1.3		g
Input threshold voltage	active high	80			% V_{DD}
Temperature sensor					
Output voltage @20°C		1.20	1.23	1.26	V
Sensitivity			-4.0		mV/°C
Output current load				10	µA
Output capacitive load				10	pF
Reset					
Input threshold voltage	active low			20	% V_{DD}
Power requirements					
Supply voltage (V_{DD})		3.2	3.3	3.4	V
Supply current (I_{DD})			3	4	mA
Accelerometer outputs					
Output voltages	OutP, OutN over full scale	0.14		3.16	V
Differential output	Over full scale		±2.7		V
Resistive load		1000			kΩ
Capacitive load				100	pF

Table 3: TS1010T Specifications

Absolute maximum ratings

Absolute maximum ratings are stress ratings. Stress in excess of the environmental specifications in the datasheet can cause permanent damage to the device. Exposure to the maximum ratings for an extended period of time may degrade the performance and affect reliability.

Parameter	Comments	Min	Typ	Max	Unit
Supply voltage (V _{DD})		-0.3		3.9	V
Voltage at any PIN		-0.3		V _{DD} +0.3	V
Operational temperature		-40		150	°C
Survival temperature	Intermittent (50 hours @ 175°C)	-55		175	°C
Vibration	Random, 10-2'000Hz			20	grms
Multiple Shock	Functional operation after 500 shocks (0.5ms / half-sine / any axis)			1'500	g
Shock Survivability	Single shock 0.15ms half-sine, in one direction (HA, PA or IA axes)			6'000	g
ESD stress	HBM model	-1		1	kV

Table 4: Absolute maximum ratings

Typical performances characteristics

TS1002T:

Typical performances on multiple sensor at 3.3 VDC supply voltage (V_{DD}) and ambient temperature for all graphs, unless otherwise stated (multiple sensor: blue line / min/max: red line / typical value: green line).

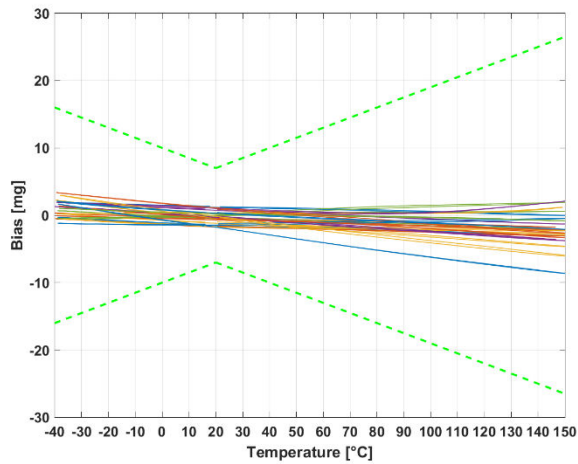

Figure 1: Raw Bias over temperature

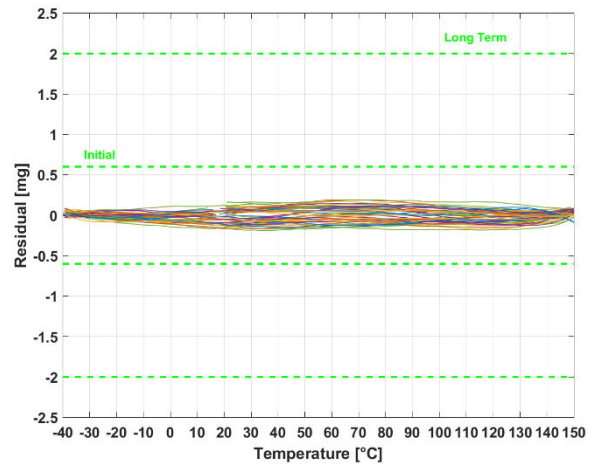

Figure 2 : Residual Bias over temperature

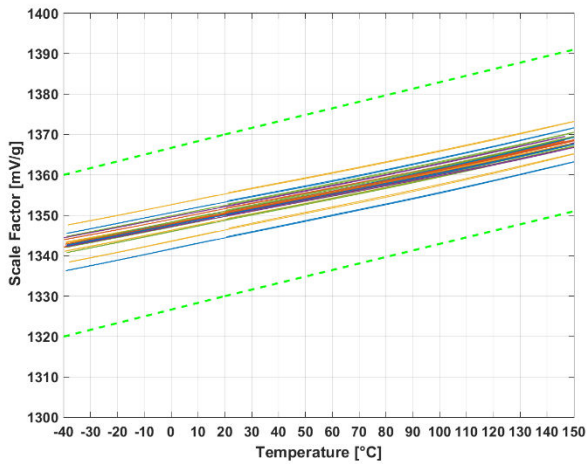

Figure 3: Raw Scale Factor over temperature

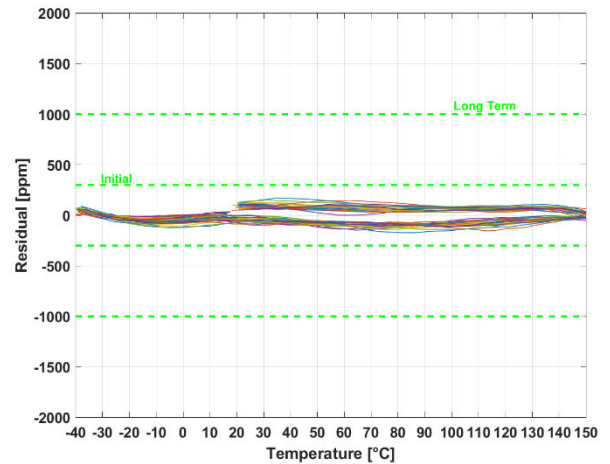

Figure 4: Residual Scale Factor over temperature

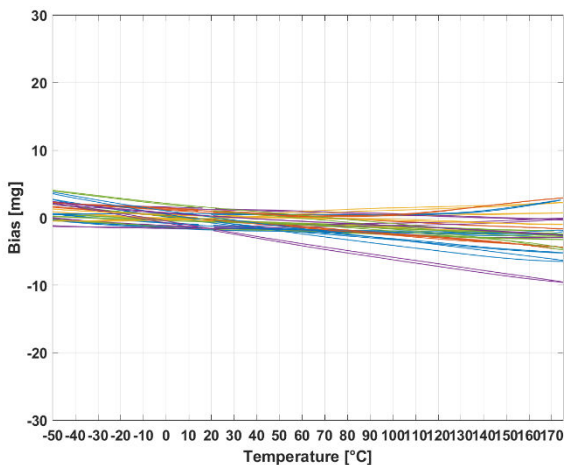

Figure 5 : Raw Bias up to intermittent 175°C

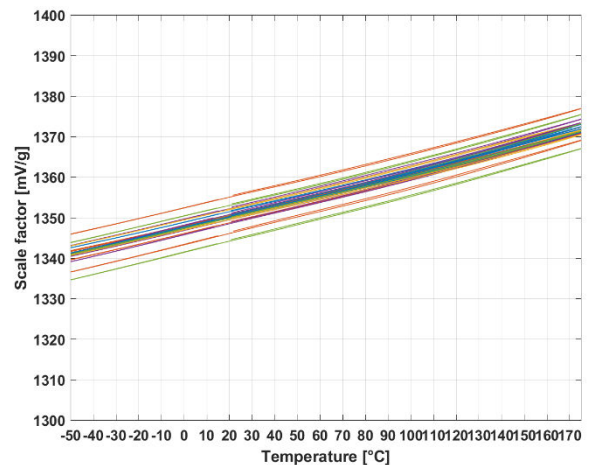

Figure 6: Raw Scale Factor up to intermittent 175°C

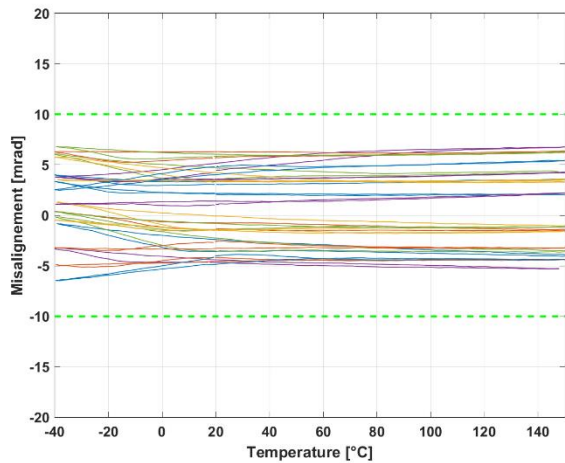

Figure 7: Raw Misalignment over temperature

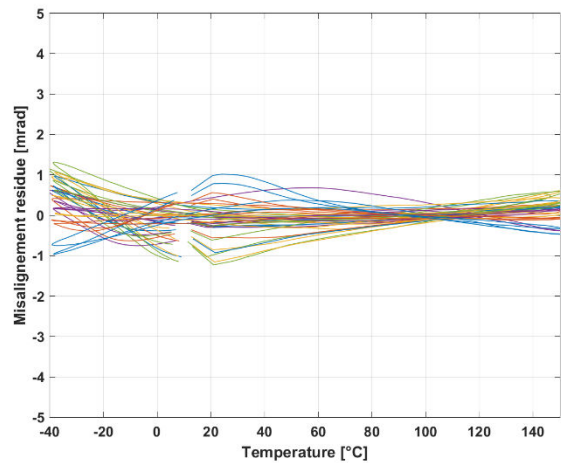

Figure 8: Residual Misalignment over temperature

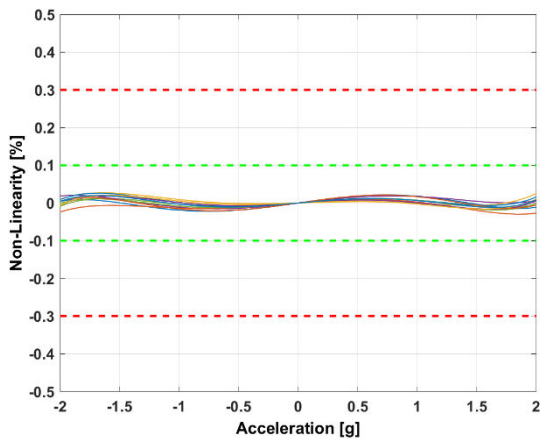

Figure 9 : Non-linearity under vibration

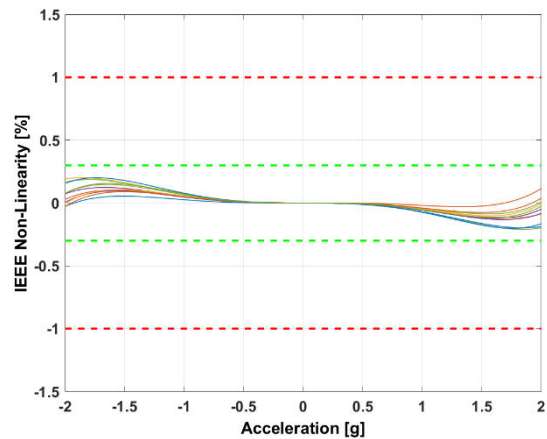

Figure 10 : Non-linearity IEEE

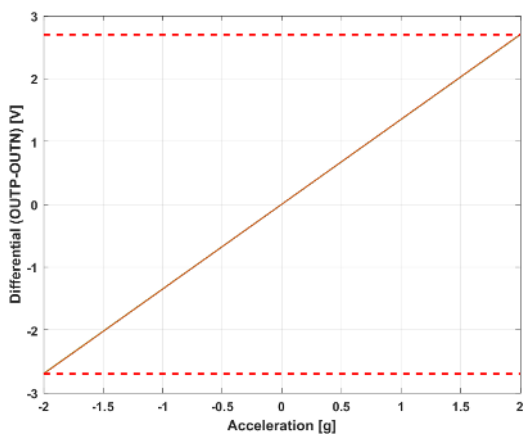

Figure 11 : Differential acceleration output (OUTP-OUTN) at full scale

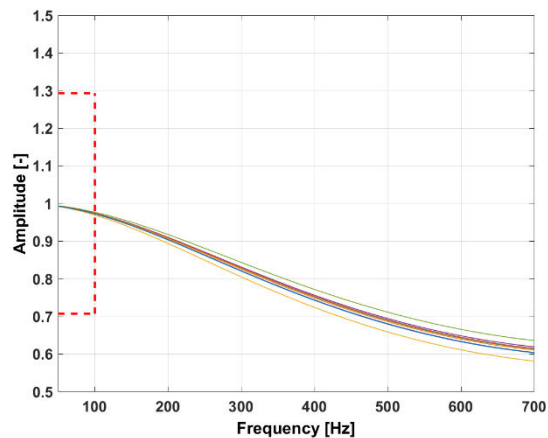

Figure 12 : Frequency response

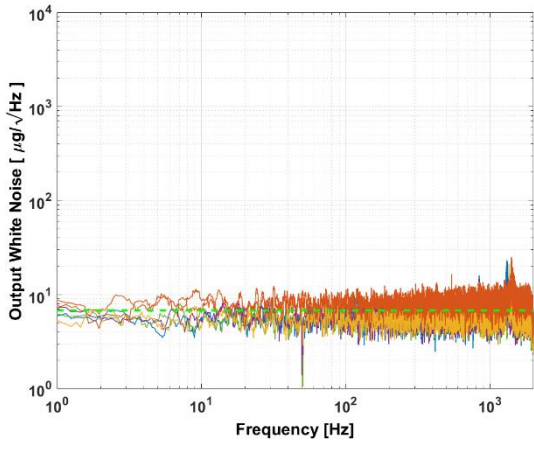

Figure 13: Typical white noise

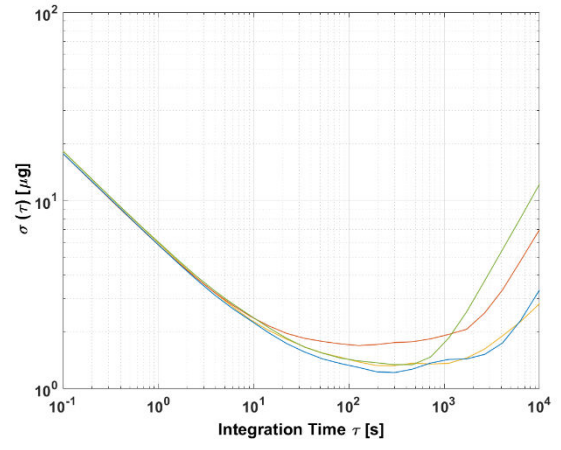

Figure 14: Allan Variance

Typical performances characteristics

TS1005T:

Typical performances on multiple sensor at 3.3 VDC supply voltage (V_{DD}) and ambient temperature for all graphs, unless otherwise stated (multiple sensor: blue line / min/max: red line / typical value: green line).

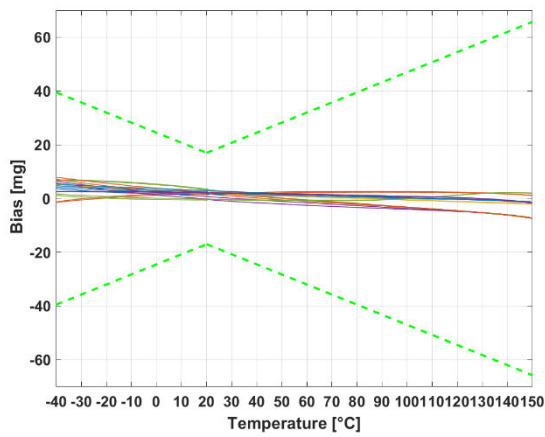

Figure 15: Raw Bias over temperature

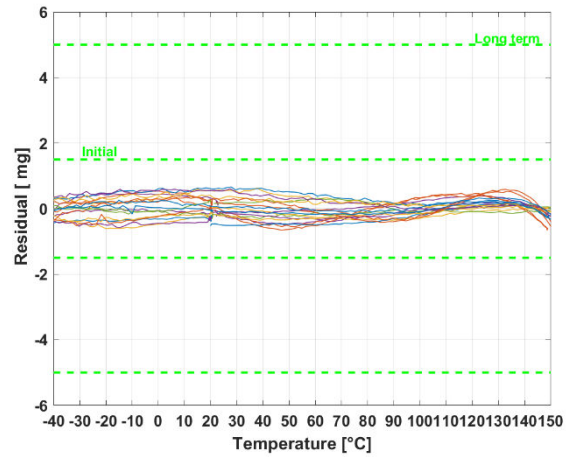

Figure 16 : Residual Bias over temperature

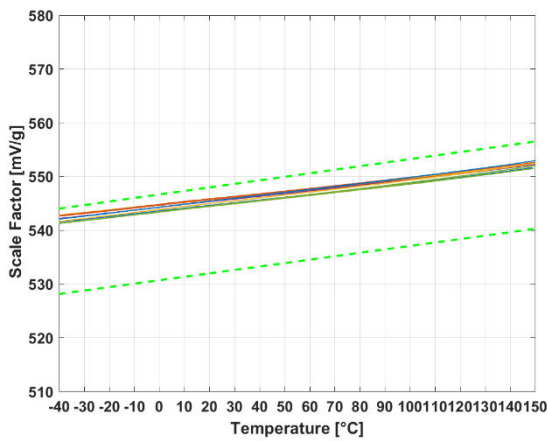

Figure 17: Raw Scale Factor over temperature

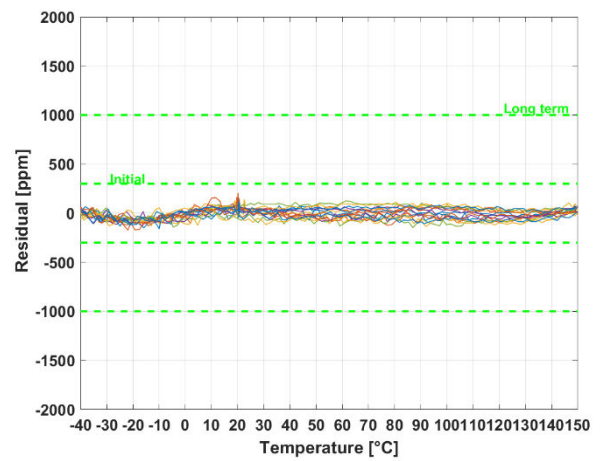

Figure 18: Residual Scale Factor over temperature

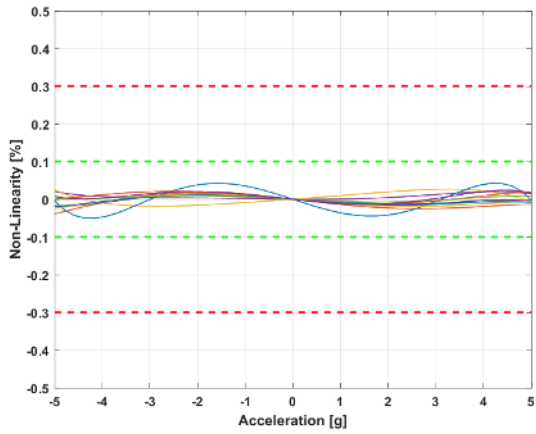

Figure 19 : Non-linearity under vibration

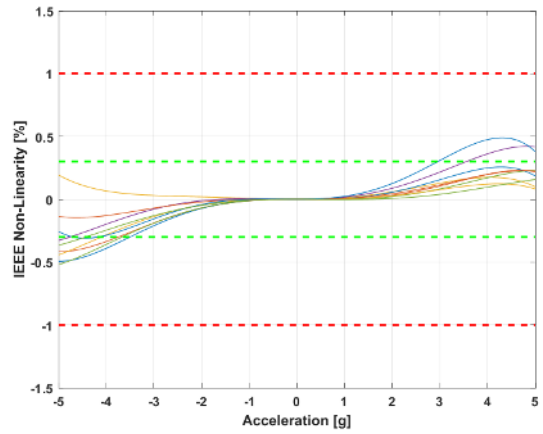

Figure 20 : Non-linearity IEEE

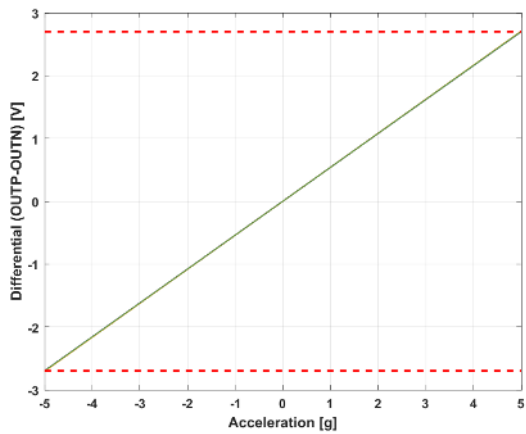

Figure 21 : Differential acceleration output (OUTP-OUTN) at full scale

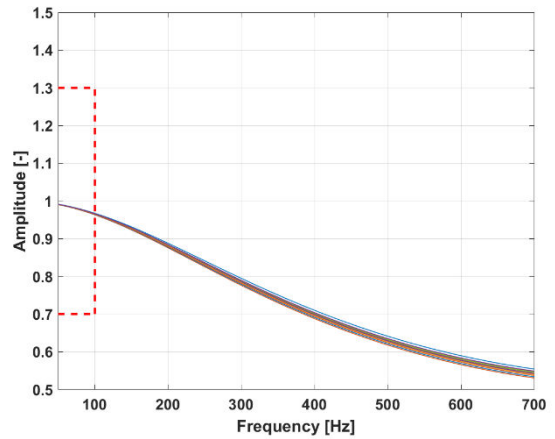

Figure 22 : Frequency response

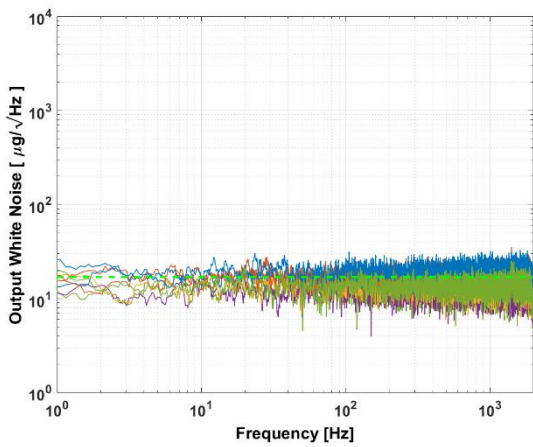

Figure 23: Typical white noise

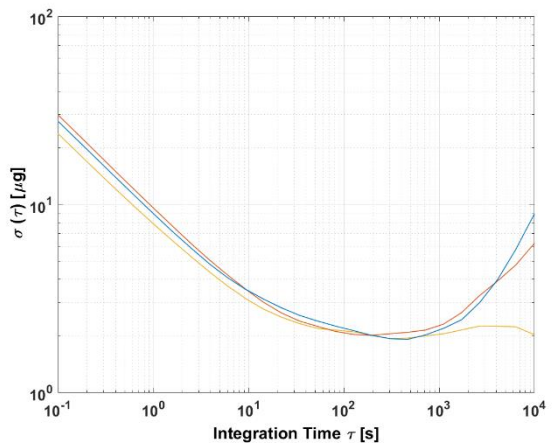

Figure 24: Allan Variance

Typical performances characteristics

TS1010T:

Typical performances on multiple sensor at 3.3 VDC supply voltage (V_{DD}) and ambient temperature for all graphs, unless otherwise stated (multiple sensor: blue line / min/max: red line / typical value: green line).

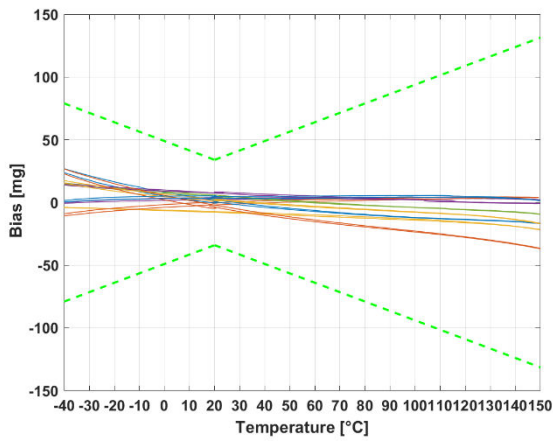

Figure 25: Raw Bias over temperature

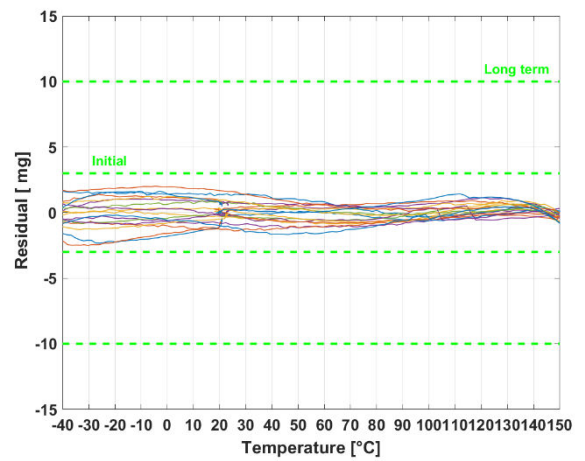

Figure 26 : Residual Bias over temperature

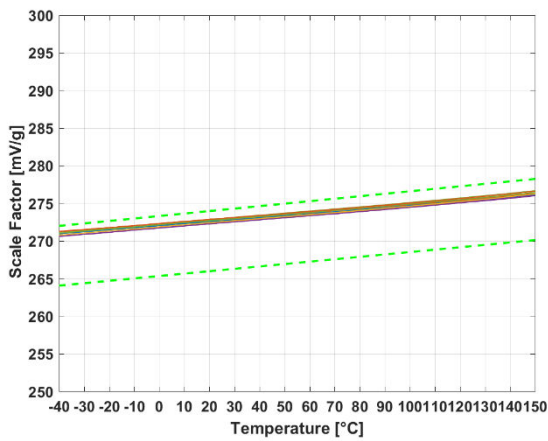

Figure 27: Raw Scale Factor over temperature

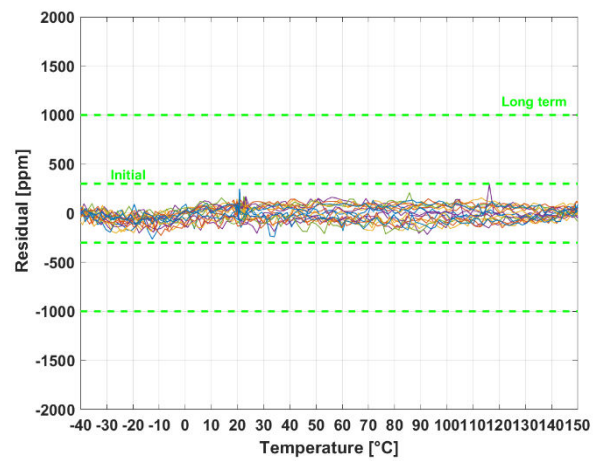

Figure 28: Residual Scale Factor over temperature

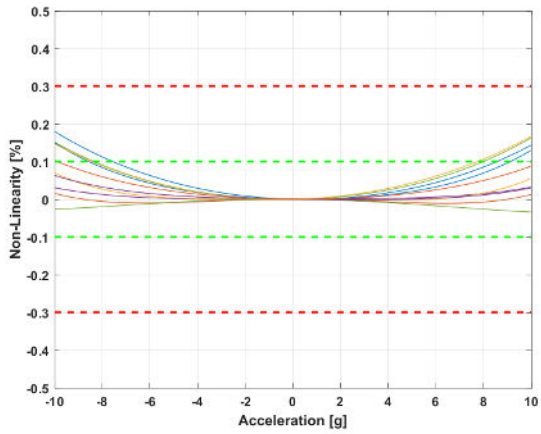

Figure 29 : Non-linearity under vibration

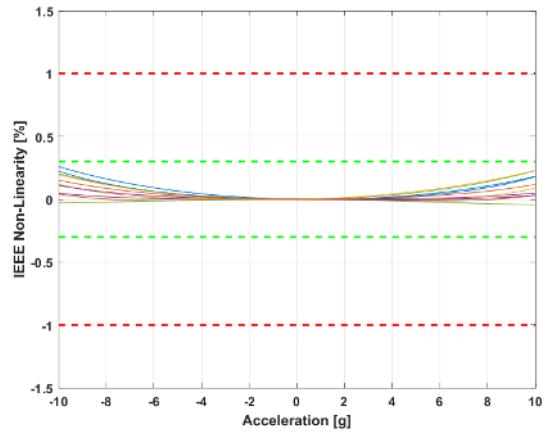

Figure 30 : Non-linearity IEEE

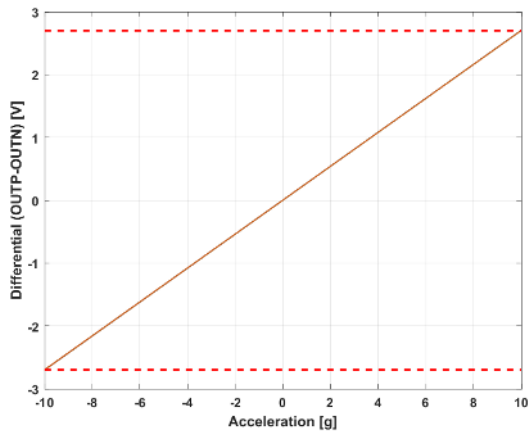

Figure 31 : Differential acceleration output (OUTP-OUTN) at full scale

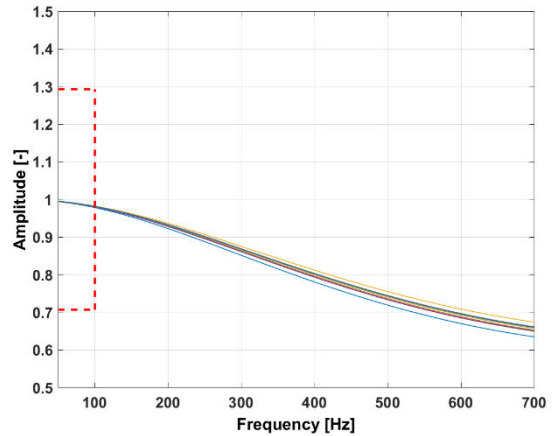

Figure 32 : Frequency response

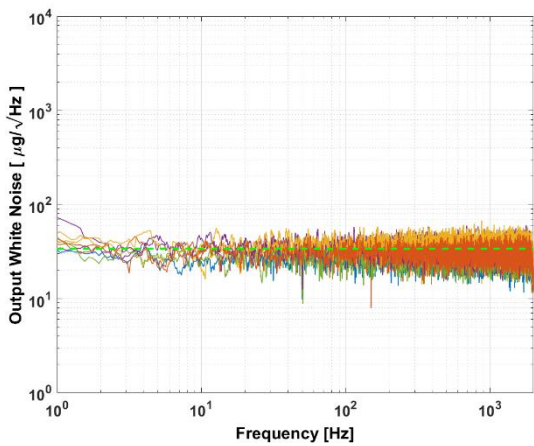

Figure 33: Typical white noise

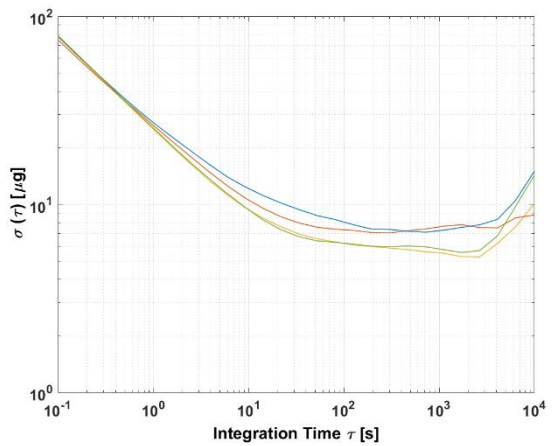

Figure 34: Allan Variance

Pinout description

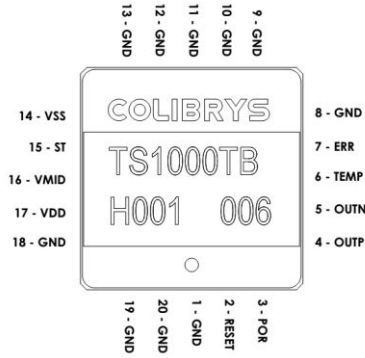

Figure 35: Pinout top view

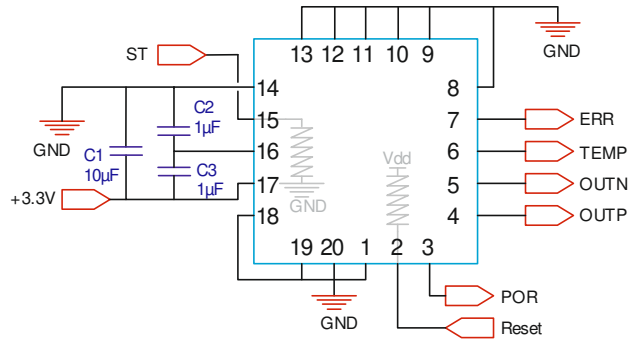

Figure 36: Proximity circuit & internal pull-up/down

The device pin layout is given in Figure 35 and a description of each pin given in the Table 5. The capacitors C1 (10 µF), C2 (1 µF) and C3 (1 µF) are shown in Figure 36 and must be placed as close as possible to the TS1000T package and are used as decoupling capacitors and for a proper sensor startup.

Pin Nb.	Pin name	Type	Description
2	RESET	LI, PU	System reset signal, active low
3	POR	LO	Power On Reset
4	OUTP	AO	Differential output positive signal
5	OUTN	AO	Differential output negative signal
6	TEMP	AO	Temperature analogue output
7	ERR	LO	Error signal (flag)
14	V _{SS} (0 V)	PWR	Connect to ground plane
15	ST	LI, PD	Self-test activation, active high
16	V _{MID}	AO	Internal electronic circuit reference voltage. For decoupling capacitors only
17	V _{DD} (3.3 V)	PWR	Analogue power supply
1,8,9,10,11, 12,13,18,19,20	GND	GND	Must be connected to ground plane (GND)

PWR, power / AO, analog output / AI, analog input / DO, digital output / DI, digital input / PD, internal pull down / PU, internal pull up

Table 5: TS1000T pinout description

Electrical Functions description

Introduction

TS1000T has electrical digital function embedded such as Power-On-Reset, External reset, Built in Self-test and Overload error detection. All those functions are described below.

POR (Power-On-Reset) function

The POR block continuously monitors the power supply during startup as well as normal operation. It ensures a proper startup of the sensor and acts as a brownout protection in case of a drop in supply voltage.

During sensor power on, the POR signal stays low until the supply voltage reaches the POR threshold voltage (V_{TH}) and begins the startup sequence (see Figure 37). In case of a supply voltage drop, the POR signal will stay low until the supply voltage exceeds V_{TH} and is followed by a new startup sequence. The ERR signal is high (equal to V_{DD}) until the startup sequence is complete.

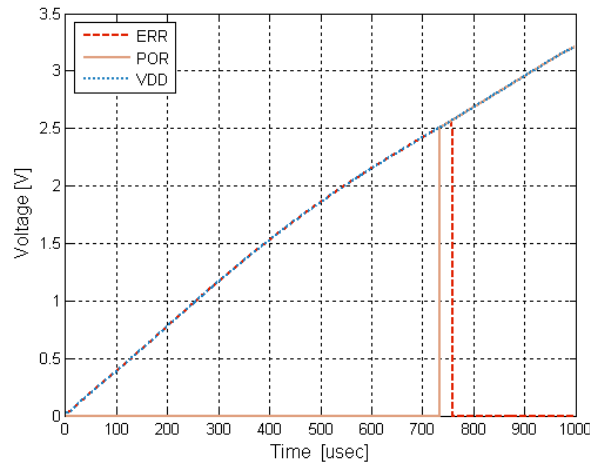

Figure 37: Typical sensor power sequence using the recommended circuit

External Reset

An external reset can be activated by the user through the RESET input pin. During a reset phase, the accelerometer outputs (OUTP & OUTN) are forced to $V_{DD} / 2$ and the error signal (ERR) is activated (high), see Figure 38.

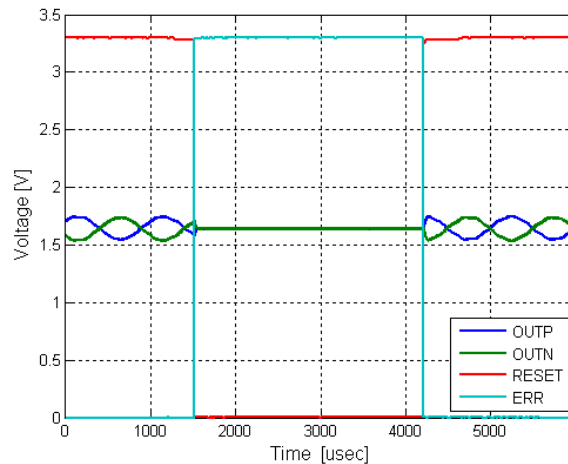

Figure 38: Typical sensor reset sequence with external reset

Built-in Self-Test function

The built-in Self-Test mode generates a square wave signal on the device outputs (OUTP & OUTN) and can be used for device failure detection (see Figure 39).

When activated, it induces an alternating electrostatic force on the mechanical sensing element and emulates an input acceleration at a defined frequency. This electrostatic force is in addition to any inertial acceleration acting on the sensor during self-test; therefore it is recommended to use the self-test function under quiescent conditions.

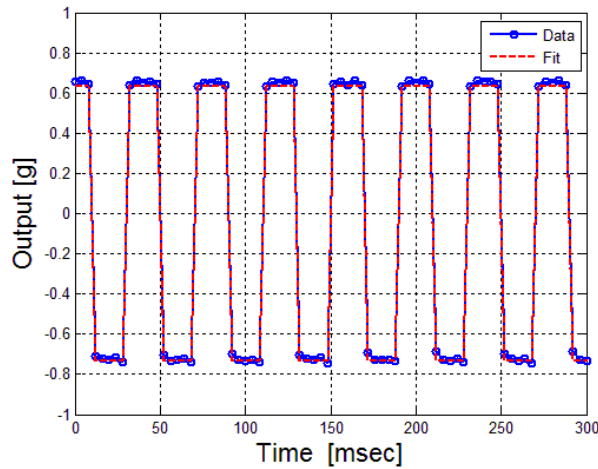

Figure 39: Built-in Self-Test signal on the differential acceleration output (frequency: 24 Hz / amplitude 1.3 g)

Overload and error function

The device continuously monitors the validity of the accelerometer output signals. If an error occurs, the ERR pin goes high and informs the user that the output signals are not valid. An error can be raised in the following cases:

- Out-of-tolerance power supply voltage (POR low), such as during power on
- During external reset phase (user activation of the reset)
- Under high acceleration overload (e.g. high shock)

Upon a high-amplitude shock, the internal overload circuit resets the electronics and initiates a new startup of the readout electronics. This sequence is repeated until the acceleration input signal returns to normal operation range. This behavior is illustrated on the figure below with a large shock of amplitude 1'500 g: the overload protection is active during the shock and the sensor is fully operational once the acceleration is within the operating range

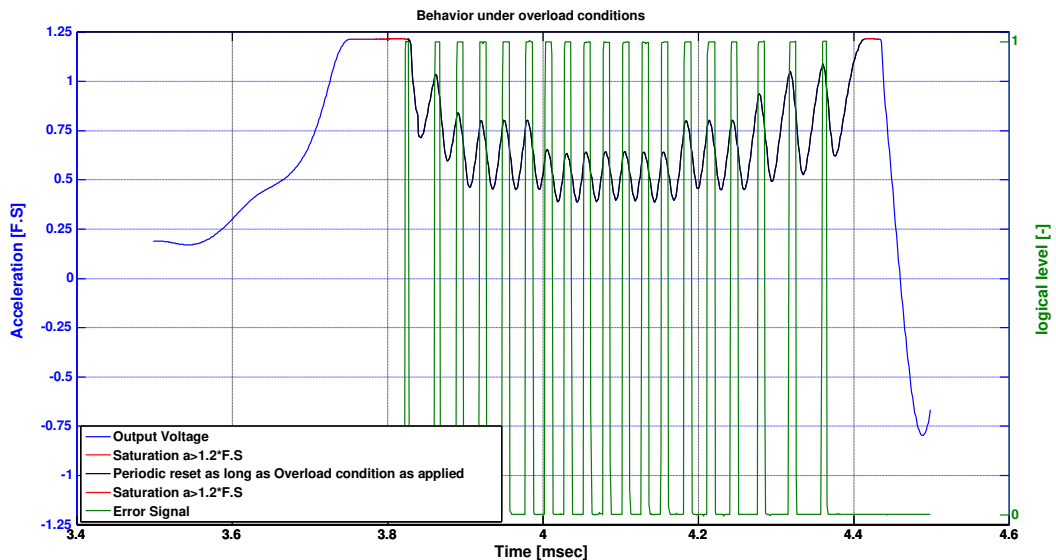

Figure 40: Overload Behavior

Dimensions and package specifications

The outline of the LCC20 ceramic package and the Center of the Proof Mass (●) are illustrated in the Figure 41.

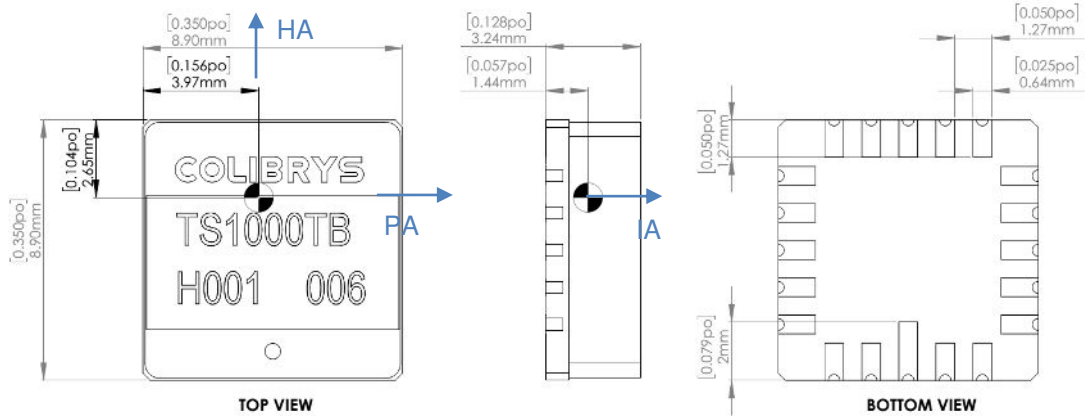

Figure 41: Package mechanical dimension. Units are mm [inch]

Parameter	Comments	Min	Typ	Max	Unit
Lead finishing	Au plating	0.5		1.5	μm
	Ni plating	1.27	4	8.89	μm
	W (tungsten)	10		15	μm
Hermeticity	According to MIL-STD-833-G			5·10 ⁻⁸	atm·cm ³ /s
Weight				1.5	grams
Size	X		8.9	9.2	mm
	Y		8.9	9.2	mm
	Z		3.23	3.5	mm
Packaging	RoHS compliant part. Nonmagnetic, LCC20 pin housing.				
Proximity effect	The sensor is sensitive to external parasitic capacitance. Moving metallic objects with large mass or parasitic effect in close proximity of the accelerometer (mm range) must be avoided to ensure best product performances. A ground plane below the accelerometer is recommended as a shielding.				
Reference plane for axis alignment	LCC must be tightly fixed to the ceramic board, using the bottom of the housing as the reference plane for axis alignment. Using the lid as reference plane or for assembly may affect specifications and product reliability (i.e. axis alignment and/or lid soldering integrity)				

Table 6: Package specifications

Recommended circuit

In order to obtain the best device performance, particular attention must be paid to the proximity analog electronics, which includes the reference voltage, the sensor decoupling capacitors and the output buffers (see block diagram in Figure 42).

Optimal acceleration measurements are obtained using the differential output (OUTP – OUTN). If a single-ended acceleration signal is required, it must be generated from the differential acceleration output in order to remove the common mode noise.

Block Diagram

The main blocks that require particular attention are the power supply management, the accelerometer sensor electronic and the output buffer. The following schematic shows an example of TS1000T implementation.

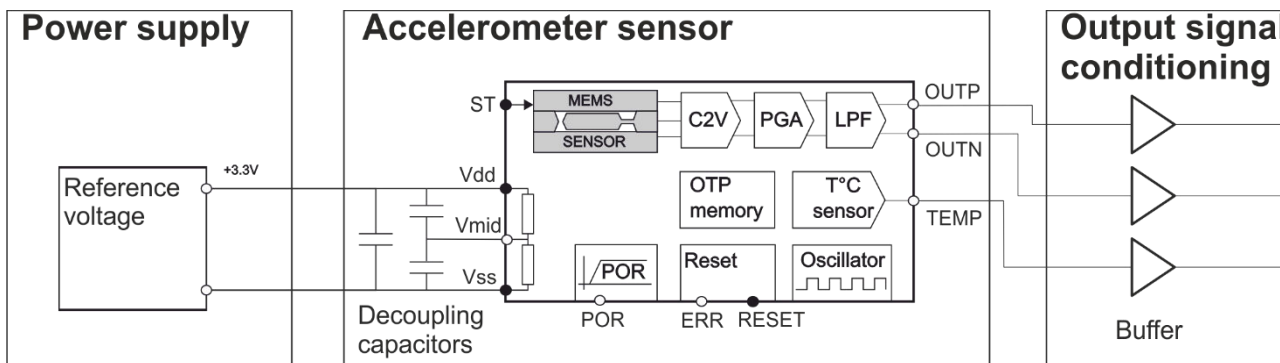

Figure 42: Block diagram

Power Supply

The accelerometer output is ratiometric to the power supply voltage and its performance will directly impact the accelerometer bias, scale factor, noise and thermal performance. Therefore, a low-noise, high-stability and low-thermal drift power supply is recommended. Key performances are:

- Output noise < 1 μ V/ $\sqrt{\text{Hz}}$
- Output temperature coefficient < 10ppm/ $^{\circ}\text{C}$

The power supply can be used as an output signal (V_{DD}) in order to compensate any variation on the power supply voltage that will impact the accelerometer signal (ratiometric output).

The electronic circuit within the accelerometer is based on a switched-capacitor architecture clocked at 200 kHz. High-frequency noise or spikes on the power supply will affect the outputs and induce a signal within the device bandwidth.

Accelerometer sensor

The sensor block is composed of the TS1000T accelerometer and the 3 decoupling capacitors: C1, C2 and C3. These capacitors are mandatory for the proper operation and full performance of the accelerometer. We recommend placing them as close as possible to the TS1000T package on the printed circuit board.

Output signal conditioning

The output buffer must be correctly selected in order to match the TS1000T output impedance and signal bandwidth. If an analog to digital converter is involved, we recommend using a component with an external voltage reference – which shall be derived from the power supply of the accelerometer V_{DD}. Such an implementation takes into account by design the ratiometric behavior of the accelerometer output.

Temperature compensation

The TS1000T delivers an output signal without any internal temperature compensation. The intrinsic temperature coefficient is quite small but can be further improved through a calibration, using the temperature provided by the internal temperature sensor. Third-order compensation is generally required for a coherent modeling of a TS1000T.

System & SMD recommendation

The stresses induced by the coefficient of thermal expansion CTE mismatch between a Printed Circuit Board (PCB) and the TS1000T ceramic package will impact global sensor performances, especially during large temperature excursions. In order to optimize stress homogeneity, minimize bias residual error and improve long-term repeatability, the sensor should be assembled on a printed circuit board (PCB) which matches the TS1000T package CTE of 7 ppm/°C.

A recommended land pattern for LCC20 is shown in the Figure 43. It should be tested and qualified in the manufacturing process. The land pattern and pad sizes have a pitch of 1.27mm and the pin 1 is longer to ensure the right orientation of the product during mounting. After assembly, the orientation can be controlled from the top with an extra point printed on the lid which correspond to pin 1. We also recommend all metal pads of the accelerometer be soldered.

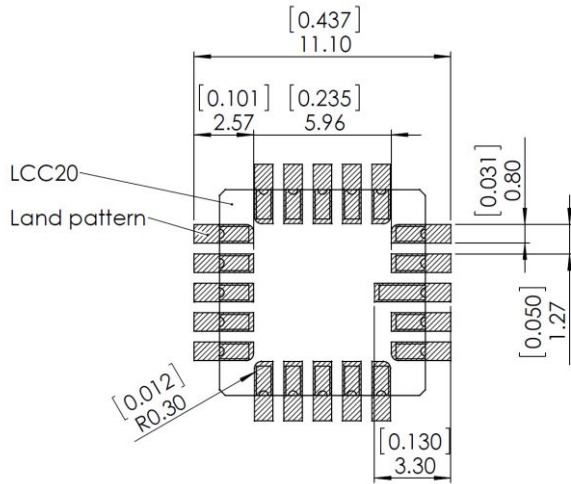

Figure 43 : LCC20 land pattern recommendation (unit are mm/[inch])

The TS1000T is suitable for Sn/Pb and Pb-Free soldering and ROHs compliant. Typical temperature profiles recommended by the solder manufacturer can be used with a maximum ramp-up of 3°C/second and a maximum ramp-down of 6°C/second: The exact profile depends on the used solder paste.

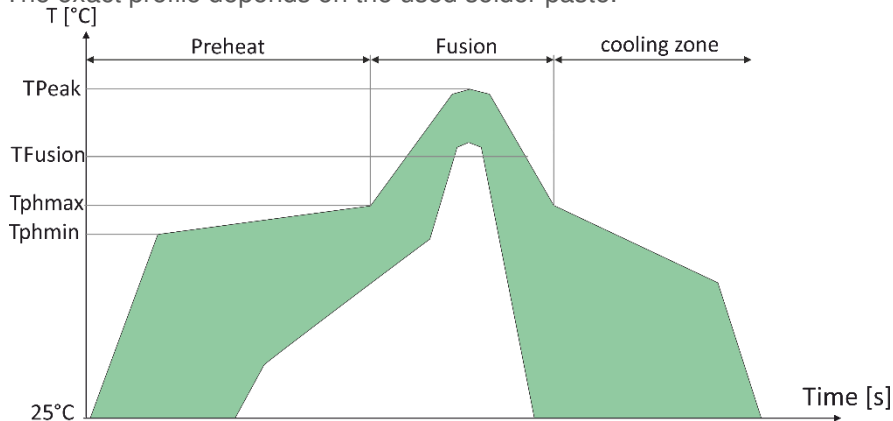

Figure 44: Soldering Temperature Profile

Phase	Sn/Pb		Pb-Free	
	Duration [sec]	Temperature [°C]	Duration [sec]	Temperature [°C]
Peak	10-30	235-240	10-30	270-290
Fusion	60-150	183	45-90	240
Preheat	60-120	Min : 100 Max : 150	100-215	Min : 150 Max : 200

Table 7: Soldering temperatures & times

An automated SMD process is mandatory to obtain good homogenous solder joints and cleaning performance that are required for the accelerometer performance. Note that cleaning process of electronic boards sometimes involves ultrasounds. This is strongly prohibited on our sensors. Ultrasonic cleaning will have a negative impact on silicon elements which generally causes damages.



Note: Ultrasonic cleaning is forbidden in order to avoid damage of the MEMS accelerometer

Handling and packaging precautions

Handling

The TS1000T is packaged in a hermetic ceramic housing to protect the sensor from the ambient environment. However, poor handling of the product can induce damage to the hermetic seal (Glass frit) or to the ceramic package made of brittle material (alumina). It can also induce internal damage to the MEMS accelerometer that may not be visible and cause electrical failure or reliability issues. Handle the component with caution: shocks, such as dropping the accelerometer on hard surface, may damage the product.



It is strongly recommended to use vacuum pens to manipulate the accelerometers

The component is susceptible to damage due to electrostatic discharge (ESD). Therefore, suitable precautions shall be employed during all phases of manufacturing, testing, packaging, shipment and handling. Accelerometer will be supplied in antistatic bag with ESD warning label and they should be left in this packaging until use. The following guidelines are recommended:

- Always manipulate the devices in an ESD-controlled environment
- Always store the devices in a shielded environment that protects against ESD damage (at minimum an ESD-safe tray and an antistatic bag)
- Always wear a wrist strap when handling the devices and use ESD-safe gloves



This product can be damaged by electrostatic discharge (ESD). Handle with appropriate precautions.

Packaging

Our device are placed for shipment and SMD process in trays. They are packed in sealed ESD-inner bag. We strongly advice to maintain our device in is original OEM sealed ESD inner-bag to guarantee storage condition before soldering them.

Product identification markings

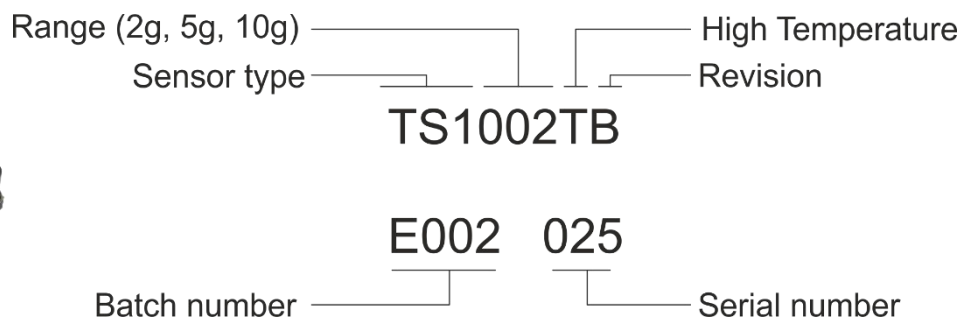

Ordering Information

Description	Product	Measurement range
Single analogue axis MEMS accelerometer, High temperature 	TS1002TB	±2g
	TS1005TB	±5g
	TS1010TB	±10g

Using TS1000T for Tilt Application

Using the acceleration signal of TS1000T accelerometer to extract the sensor heading requires 2 steps:

- Step1 : Sensor modelling
- Step2 : Signal compensation

The following model describes tilt estimation using 2 axes ($A_h=0$). The generic model can be simplified within the 1st step, the non-idealities of the sensor will be modelled during a temperature cycle.

K_0 , K_1 , K_2 , K_3 , K_P and K_{SP} will be modelled with respect to the output of the TEMP pin assuming the 2axes model below:

$$\frac{OUT_P - OUT_N}{V_{DD}} * 3.3 = K_1(T) * [K_0(T) + A_s + K_2(T) * A_s^2 + K_3(T) * A_s^3 + K_p(T) * A_p + K_{sp}(T) * A_p * A_s + E]$$

The compensation model uses a 3rd order polynomial for $K_0(T)$, $K_1(T)$, $K_2(T)$, $K_3(T)$ a 1st order for $K_P(T)$ and a constant for K_{sp} . The 2nd step consists in subtracting all the modelled errors of the 1st step and to convert the obtained signal into an angular vector. The compensation model is given in the figure below.

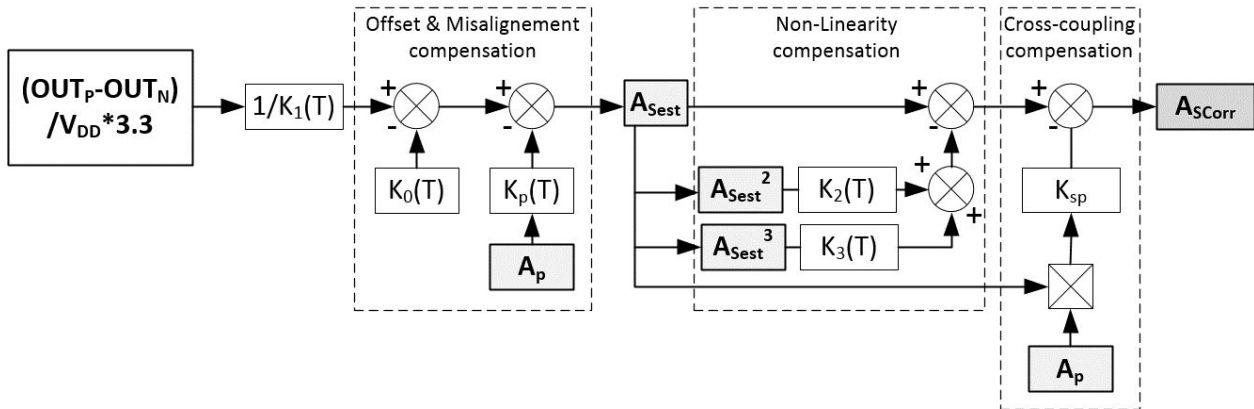

Figure 45 : Recommended compensation scheme

T or TEMP correspond to the voltage measured on the TEMP pin of the sensor.

A_{Sest} corresponds to the acceleration estimated using only K_0 , K_1 and K_P compensation.

A_{Scorr} corresponds to the detected acceleration compensated from all modelled errors.

The transformation from acceleration (g) to angle ($^\circ$) can be done using the arctangent function.

$$\theta = \arctan\left(\frac{A_{Scorr}}{A_p}\right)$$

The angular performances obtained using the recommended compensation scheme shows an angular accuracy well below 0.1° .

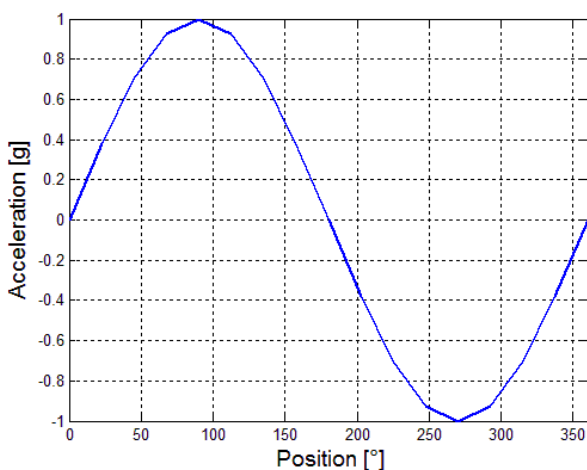

Figure 46: Position to acceleration conversion

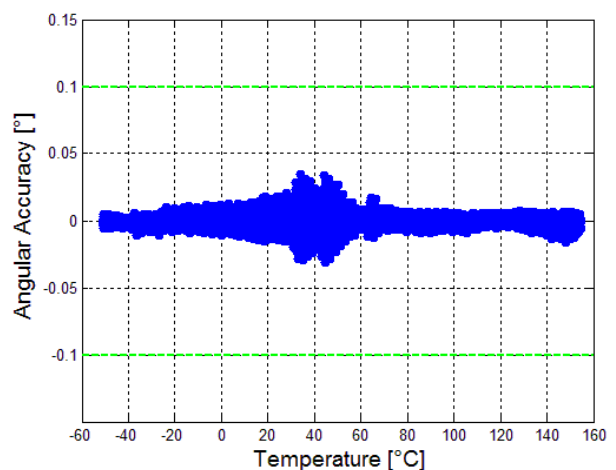

Figure 47: Angular accuracy over temperature of a TS1002TA sensor

Glossary of parameters of the Data Sheet

Accelerometer model

$$\frac{OUT_P - OUT_N}{V_{DD}} * 3.3 = K_1(K_0 + A_s + K_2 \cdot A_s^2 + K_3 \cdot A_s^3 + K_p \cdot A_p + K_h * A_h + K_{sp} * A_s A_p + K_{sh} * A_s A_h + E)$$

A_s, A_p, A_h are the accelerations for each axes of the sensor with:

Input Axis (IA): Sensitive axis

Pendulous Axis (PA): Aligned with the proof mass beam and perpendicular to the input axis

Hinge Axis (HA): Perpendicular to the input and pendulous axes. Direction of the dot.

K_1 is accelerometer scale factor [V/g]

K_0 is bias [g]

K_2 is second order non-linearity [g/g²]

K_3 is third order non-linearity [g/g³]

K_p is pendulous cross-axis [rad]

K_h is output cross-axis [rad]

K_{sp}, K_{io} are cross-coupling coefficients [rad/g]

E is the residual noise [g]

g [m/s²]

Unit of acceleration, equal to standard value of the earth gravity (Accelerometer specifications and data supplied by Safran Sensing Technologies Switzerland SA use 9.80665 m/s²).

Bias [mg]

The accelerometer output at zero g.

Bias temperature coefficient [mg/°C]

Variation of the bias under variable external temperature conditions (slope of the best fit straight line through the curve of bias vs. temperature).

Scale factor [mV/g]

The ratio of the change in output (in volts) to a unit change of the input (in units of acceleration); thus given in mV/g.

Scale factor temperature coefficient [ppm/°C]

Maximum deviation of the scale factor under variable external temperature conditions.

Temperature sensitivity

Sensitivity of a given performance characteristic (typically scale factor, bias, or axis misalignment) to operating temperature, specified generally at 20°C. Expressed as the change of the characteristic per degree of temperature change; a signed quantity, typically in ppm/°C for scale factor and mg/°C for bias. This figure is useful for predicting maximum scale factor error with temperature, as a variable when modelling is not accomplished.

Non-linearity, under vibration [% FS]

The maximum deviation of accelerometer output from the best linear fit over the full scale input acceleration (sinusoidal input). The deviation is expressed as a percentage of the full-scale output (+ A_{FS}).

Non-linearity, IEEE [% FS]

Absolute maximum error versus full-scale acceleration

$$NL_{max} \equiv \left| \frac{V - K_1(K_0 + A_s)}{K_1 A_{FS}} \right|_{max} = \left| \frac{K_2 A_s^2 + K_3 A_s^3 + \dots}{A_{FS}} \right|_{max}$$

Frequency response [Hz]

Frequency range from DC to the specified value where the variation in the frequency response amplitude is less than ±3 dB

Noise [µg/√Hz]

Undesired perturbations in the accelerometer output signal, which are generally uncorrelated with desired or anticipated input accelerations.

Long-term repeatability (Bias [mg] & Scale factor [ppm])

Bias and scale factor residue over temperature [-40°C ; 150°C] after applying following environmental conditions:

- powered life test 500h @150°C
- 60x temperature cycling -40°C to 150°C
- random vibration @130°C (20grms / 10-2'000Hz)
- shock @130°C (100g / 2ms / 12'000 shocks)

Quality

Safran Sensing Technologies Switzerland is ISO 9001:2015, ISO 14001:2015 and ISO 45001:2018 certified

Safran Sensing Technologies Switzerland complies with the European Community Regulation on chemicals and their safe use (EC 1907/2006) REACH

TS1000 products comply with the EU-RoHS directive 2011/65/EC (Restrictions on hazardous substances) regulations

Recycling : please use appropriate recycling process for electrical and electronic components (DEEE)

TS1000 products are compliant with the Swiss LSPro : 930.11 dedicated to the security of products

Note:

- *TS1000 accelerometers are available for sales to professional only*
- *Les accéléromètres TS1000 ne sont disponibles à la vente que pour des clients professionnels*
- *Die Produkte der Serie TS1000 sind nur im Vertrieb für kommerzielle Kunden verfügbar*
- *Gli accelerometri TS1000 sono disponibili alla vendita soltanto per clienti professionisti*

Safran Sensing Technologies Switzerland complies with due diligence requirements of the Conflict Minerals Regulation



Disclaimer

Safran Sensing Technology Switzerland (SSTS) reserves the right to make changes to products without any further notice.

Performance may vary from the specifications provided in SSTS' datasheet due to different applications and integration. Operating performance, including long-term repeatability, must be validated for each customer application by customer's technical experts. The long-term repeatability specification expressed in the datasheet is valid only in the defined environmental conditions (cf Long-term repeatability glossary), and the performance at system level remains the customer's responsibility.

The degolding process applied to the products is excluded from SSTS recommendations. And if applied, cancels any products warranty and liability.

USE OF THE PRODUCT IN ENVIRONMENTS EXCEEDING THE ENVIRONMENTAL SPECIFICATIONS SET FORTH IN THE DATASHEET WILL VOID ANY WARRANTY. SAFRAN SENSING TECHNOLOGIES SWITZERLAND HEREBY EXPRESSLY DISCLAIMS ALL LIABILITY RELATED TO USE OF THE PRODUCT IN ENVIRONMENTS EXCEEDING THE ENVIRONMENTAL SPECIFICATIONS SET FORTH IN THE DATASHEET.

**POWERED
BY TRUST**

Safran Sensing Technologies Switzerland
sales@colibrys.com