

# Skydel RTCM

Simulation Plugin

## User Manual

Skydel Software-Defined GNSS Simulator RTCM Plugin

Document Part No: Skydel RTCM User Manual

Revision: 1

# Contents

1.	General information .....	3
2.	Skydel RTCM plugin features .....	3
3.	Connecting GNSS receiver to the simulator .....	4
	Serial port connection .....	4
	NTRIP connection .....	5
4.	Preparing Skydel base station and rover simulator configurations.....	6
	General considerations .....	6
	Rover configuration .....	6
	Base station configuration .....	7
	RTCM plugin UI .....	10
5.	Running simulations .....	10
6.	Appendix A – Receiver configuration .....	11
	Configuration of u-blox F9P .....	11
7.	Contact .....	12

## 1. General information

This manual is designed to aid customer understanding, configuration, and use of the Skydel RTCM plugin, which should be used in conjunction with the Skydel simulation software.

RTCM 3.3 (also known as RTCM 10403.3, differential GNSS services – version 3) is a standard developed by the Radio Technical Commission for Maritime Services that describes the protocol for transmission of differential corrections data allowing GNSS receivers to calculate their position with higher precision.

RTK (Real-time kinematic) is a differential positioning technique that uses carrier phase measurements in addition to the usual pseudo-range measurements to improve positioning precision.

The RTK technique is utilized by many modern GNSS receivers, together with support of the RTCM 3.3 standard.

The data contained in RTCM 3.3 messages contains carrier phase and pseudo range measurements made by a base station. The base station is a GNSS receiver that processes GNSS signals like a usual receiver, but its position is known in advance with extremely good precision. RTCM 3.3 data is then transferred from the base station to another GNSS receiver (a “rover”); the rover receiver compensates its own measurement errors and thus improves its positioning precision.

NTRIP (Network Transport of RTCM via Internet Protocol) is a protocol used to stream RTCM data over a network, including Internet.

The Skydel RTCM plugin allows simulation of RTCM 3.3 messages from a base station without the need to generate real RF signals for a base station receiver. RTCM messages can be streamed from the Skydel application to the rover receiver with either serial port connection or with NTRIP.

Two instances of the Skydel application are required to simulate GNSS constellations for both the base station and the rover. But only one instance (the one used for the rover) requires real RF output that needs to be connected to the receiver. The instance used for base station simulation can be configured to use “NoneRT” output. Future versions of Skydel may add a new mode that would give better performance for base station simulation with no RF hardware. The Skydel instances must be synchronized using the “Synchronize simulators” feature to simulate same time and same satellites orbits.

## 2. Skydel RTCM plugin features

RTCM protocol version: 3.3

Supported RTCM3 messages:

- 1006 (Base station position)
- 1033 (Receiver & antenna description)
- MSM3 messages:
  - 1073 (MSM3 GPS)
  - 1083 (MSM3 GLONASS)

- 1093 (MSM3 Galileo)
- 1123 (MSM3 BeiDou)
- 1113 (MSM3 QZSS)
- 1133 (MSM3 IRNSS)
- MSM7 messages:
  - 1077 (MSM7 GPS)
  - 1087 (MSM7 GLONASS)
  - 1097 (MSM7 Galileo)
  - 1127 (MSM7 BeiDou)
  - 1117 (MSM7 QZSS)
  - 1137 (MSM7 IRNSS)

NTRIP (to stream RTCM3 data to a client via an NTRIP protocol).

Capability to write RTCM3 data into binary or hex file.

### 3. Connecting GNSS receiver to the simulator

The Skydel RTCM plugin allows RTCM3 data to stream to a serial port (COM port) or to a network using NTRIP protocol. Depending on what type of RTCM3 output you select, various connection schemes are possible.

#### Serial port connection

In general, if you want to stream RTCM3 messages to a serial port and simultaneously be able to observe receiver status (position solution), you will need a receiver with at least two interfaces: one for RTCM3 messages and another for NMEA (or other) protocol output.

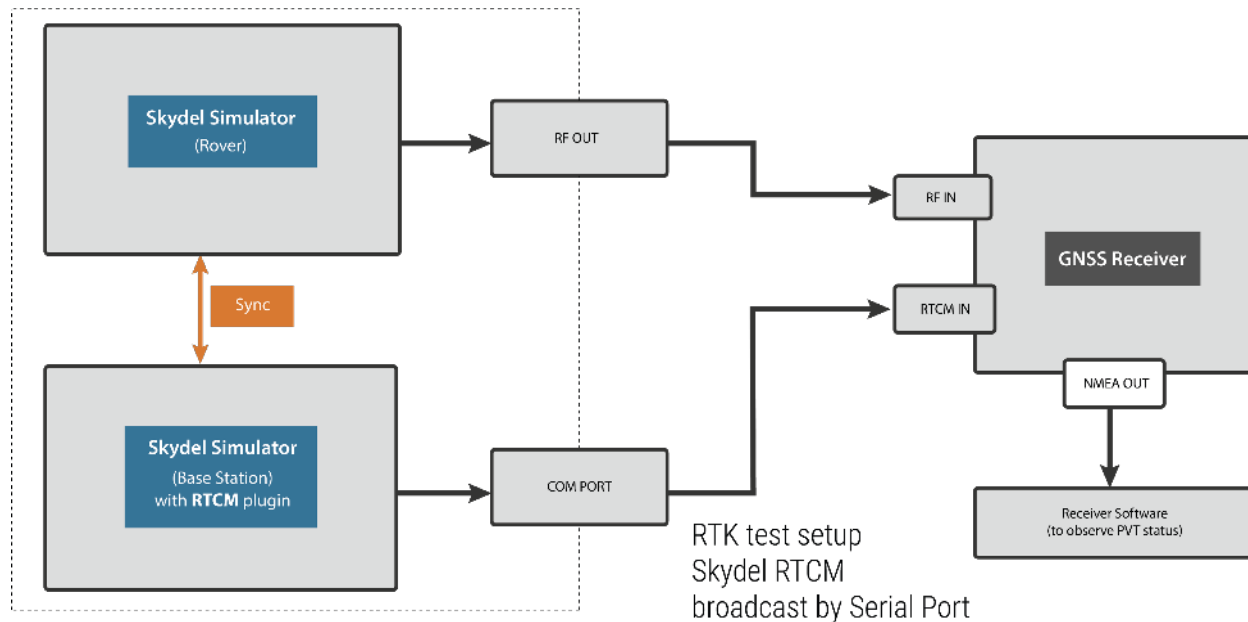

## NTRIP connection

If you want to stream RTCM data with NTRIP, you need to have NTRIP client software that will communicate with the NTRIP caster within the plugin. The NTRIP client can be either specialized NTRIP software, software from receiver vendor, or the NTRIP client can even be embedded into receiver (for receivers having network interface).

The image below describes the setup for Skydel RTCM using NTRIP communication software.

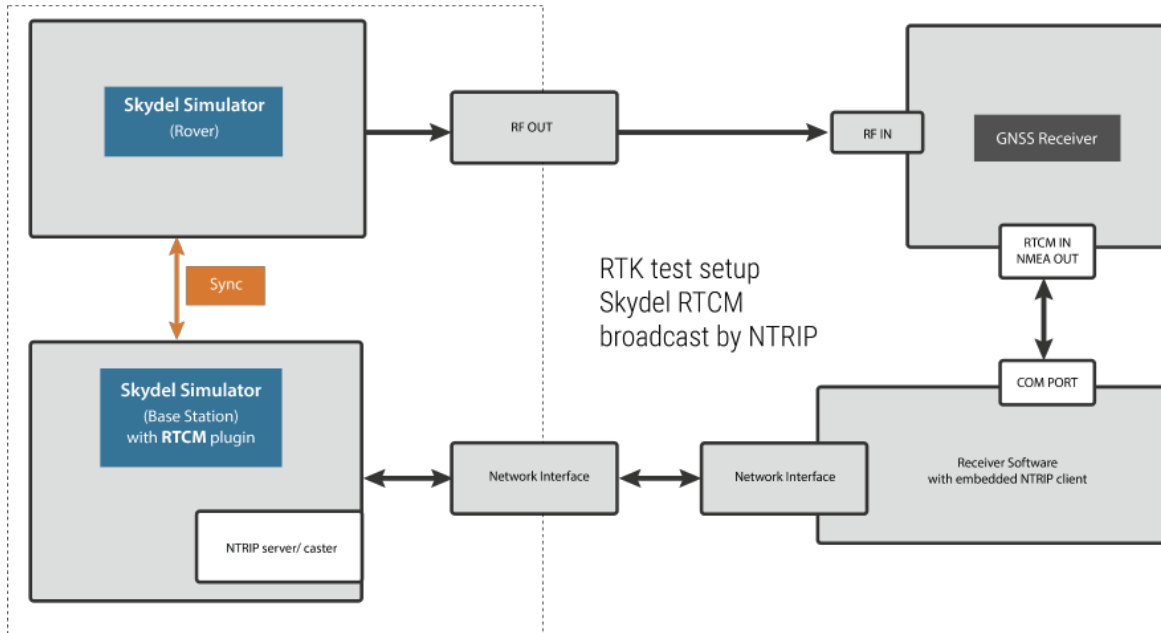

The following image depicts the test setup when the GNSS receiver contains an embedded NTRIP client.

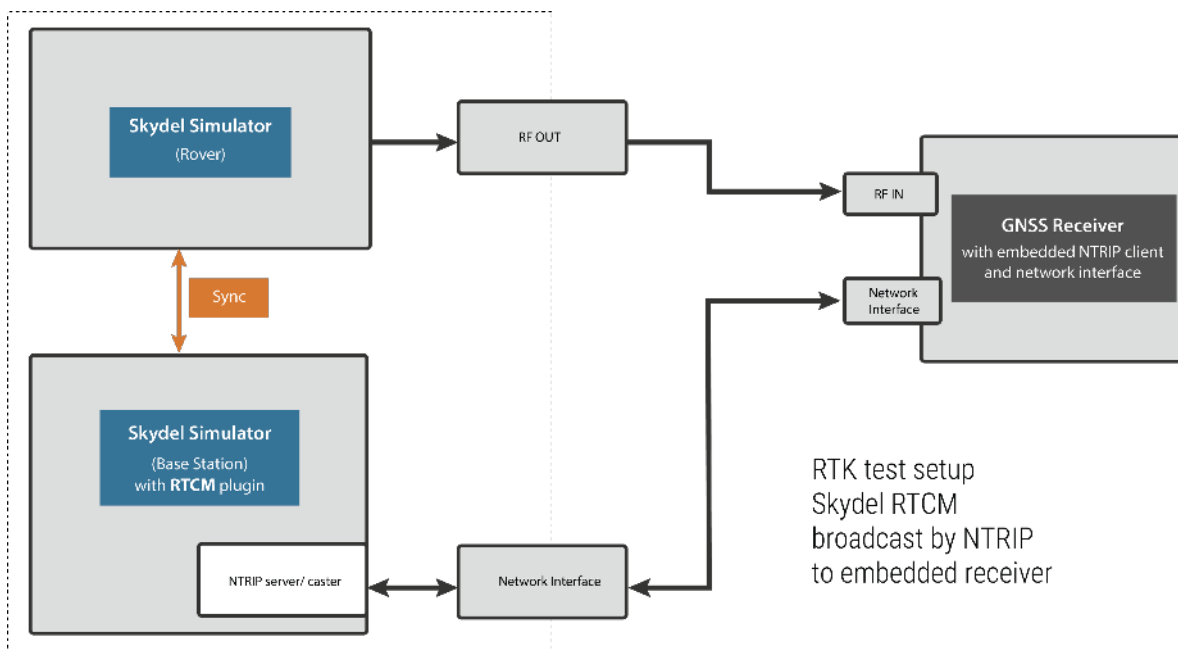

## 4. Preparing Skydel base station and rover simulator configurations.

### General considerations

**Simulated location of rover and base station.** RTK technique relies on the fact that measurement errors observed by the base station (which true location is known) approximately correspond to the measurement errors made by the rover (which location is not known and needs to be determined). This is the case when the rover is located not too far from the base station, usually not further than 10-15 km. Simulated rover positions must be within this distance from the simulated base station position. Generally, the bigger the distance, the higher the position error.

**Simulated signals set.** The RTCM plugin can output RTCM3 data only for signals configured for the base station. The signals set to be simulated for the rover must correspond (or be a subset) of the signals set simulated by the base station.

### Rover configuration

- Create a new configuration.
- Select the output type that implies real RF signal generation.
- In the output settings select the signals you want simulate for the rover.

**Sync:** Configure the rover simulator to be synchronized with base station simulator.

- Go to Settings->Global->Synchronize simulators.
- Set the checkbox “Sync time(master)”. This will allow the base station simulation to start together with the rover simulation.
- Set the checkbox “Automatically broadcast configuration on simulation start”.
- Exclude “Radios”, “Outputs and Radios”, “Vehicle motion”, “Vehicle antenna”, “Interference” and “Plug-in” from the synchronization (see following image).

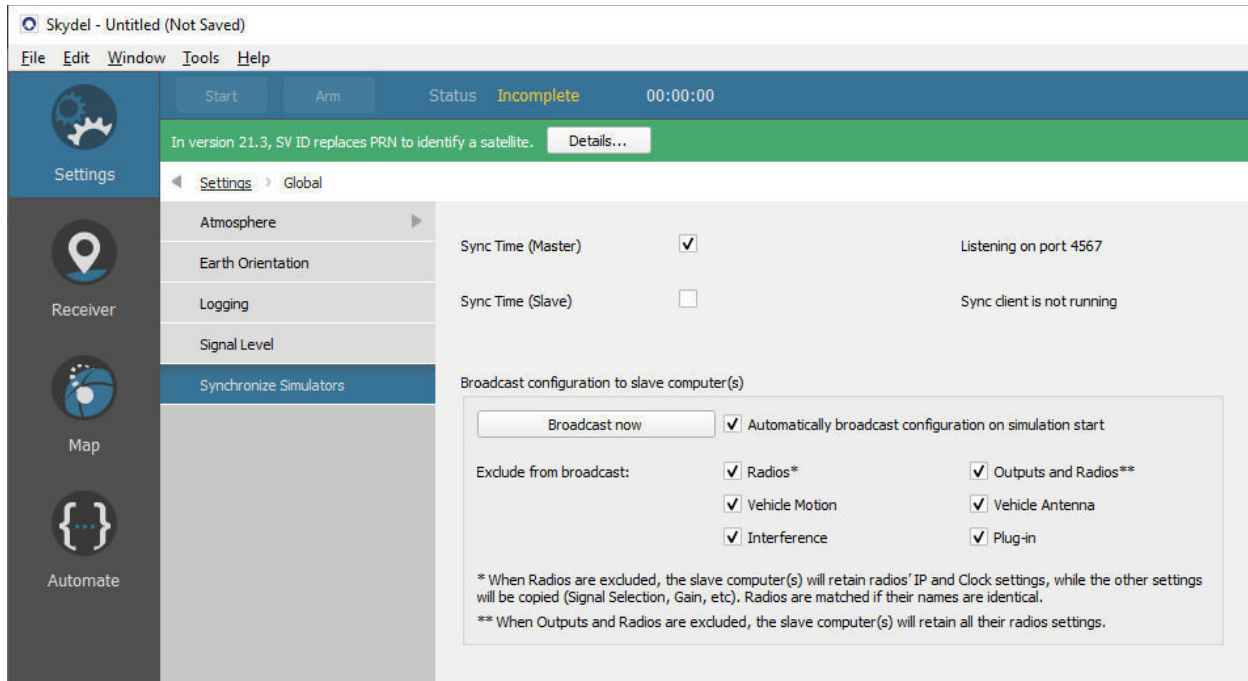

- Select rover trajectory in Settings->Vehicle->Trajectory. Keep in mind positioning precision depends on the distance between the rover and the base station.
- Save configuration in a file.

## Base station configuration

- Create new configuration. Select “NoneRT” output. In the output settings select the signals you want simulate for the base station. RTCM3 messages will contain only data for enabled signals.
- Load RTCM plugin into configuration. Go to Settings / Plug-ins and select Add Plug-in.... Set the name and type of plug-in instance and select OK. (see following image)

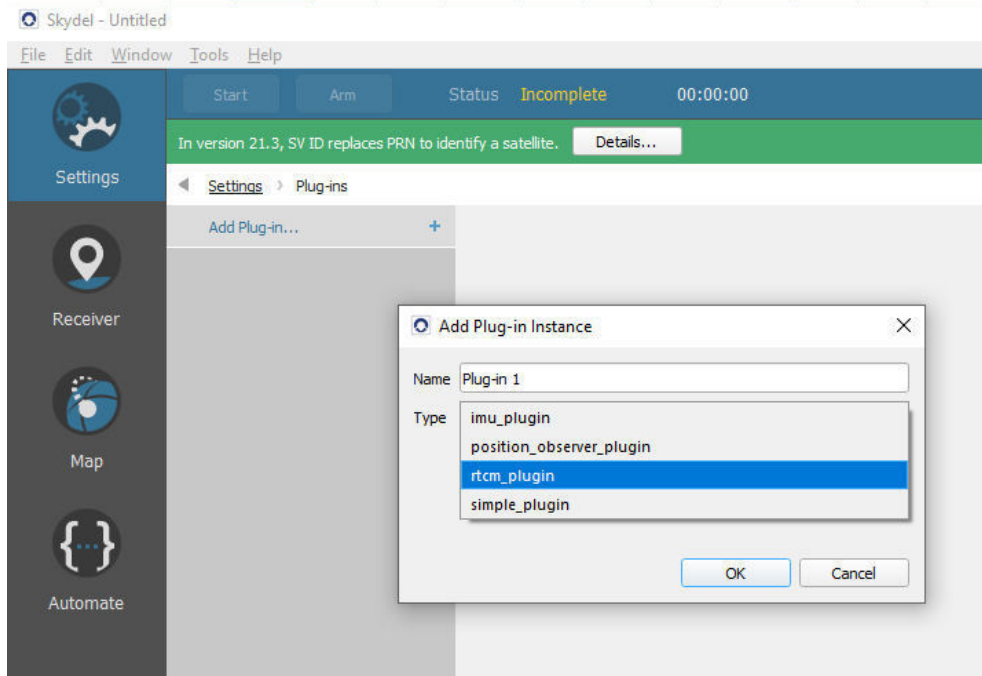

- Select the new instance:

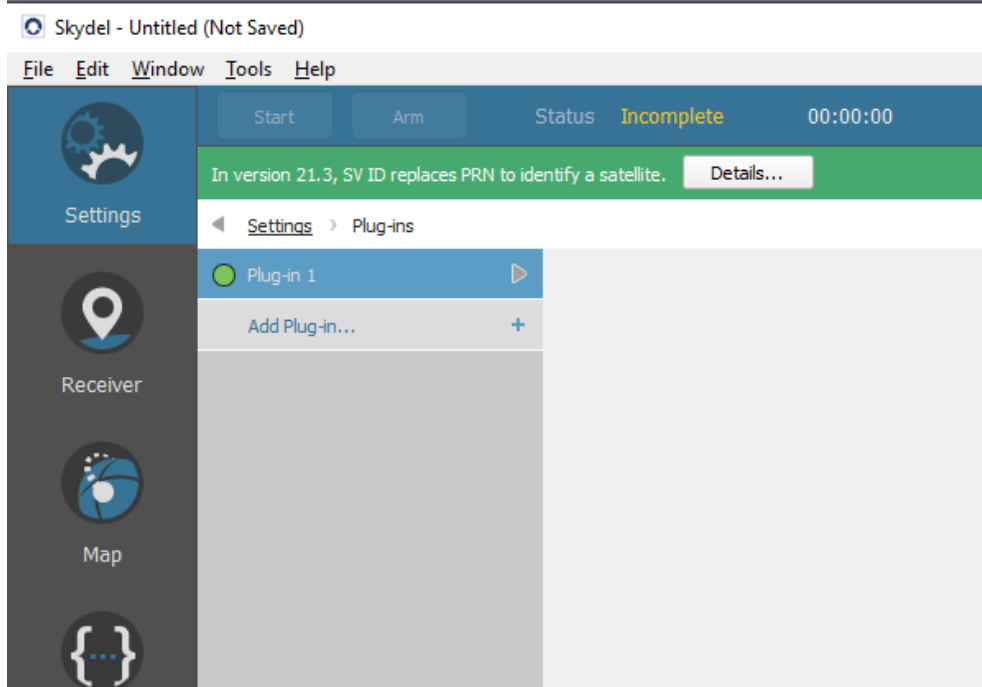

The *Plug-in UI* menu will display the plugin's interface.

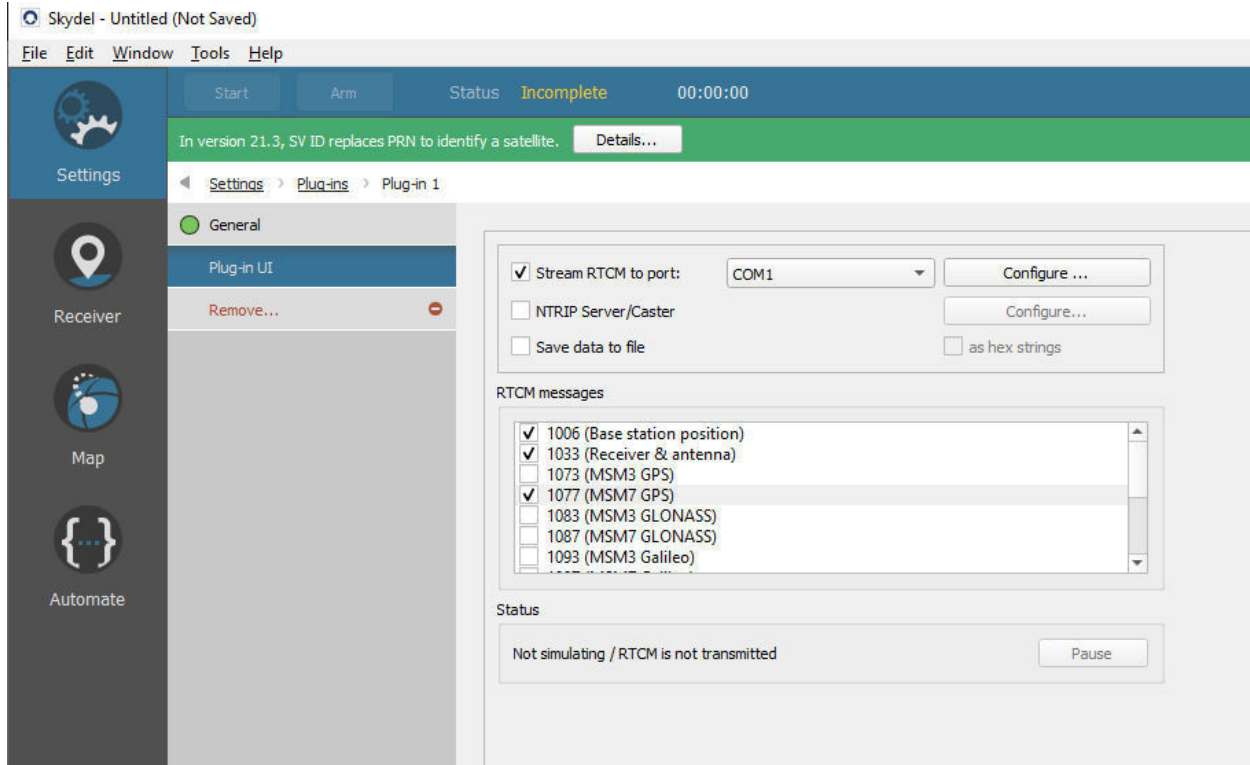

For the plugin configuration instructions, refer to the next section, “RTCM plugin UI”.

- Select base station position in Settings->Vehicle->Trajectory. Set trajectory type to “fixed”.

**Sync:** Allow base station simulator to be synchronized with rover simulator.

- Go to Settings->Global->Synchronize simulators.
- Set checkbox “Sync time(slave)”. This will allow the base station simulation to start together with the rover simulation.

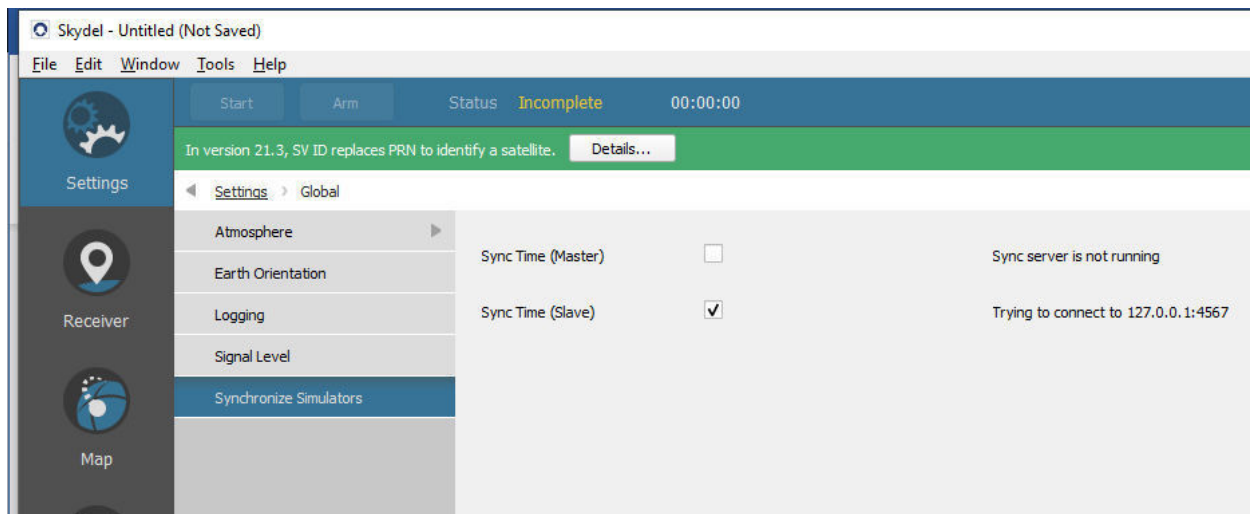

## RTCM plugin UI

The “Stream RTCM to port” line allows you to select the serial port that will receive the RTCM data stream (this is a PC serial port that must be physically connected to the receiver). Ensure that communication parameters (under “Configure” button) match the serial port parameters on the receiver side. Keep in mind that the selected baud rate should be enough to stream all selected messages in real time. Usually, 115200 is a good choice.

The “NTRIP server/Caster” selection enables the NTRIP server/caster. The “Configure” button on the right side allows you to select TCP port to accept incoming connections from NTRIP clients and allow accepting connections from other devices in the network (for example from other PC or from a network-enabled receiver with an embedded NTRIP client).

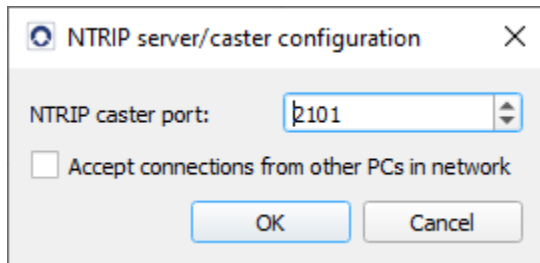

Note that the NTRIP server/caster is active only when a simulation is running. You will not be able to connect to the caster from an NTRIP client when a simulation is not running.

In the RTCM messages check list, you can select the messages to output. Message 1006 (containing the base station position) must always be enabled, unless you manually set the base station position in the receiver.

MSM7 messages contain complete measurement information with highest precision but may not be supported by all receivers. MSM3 messages contain a “compact” information set.

Usually, it makes sense to select messages that correspond to the GNSS constellation signals you selected in the output configuration. You can also select the message for other (not simulated) constellations – such messages will be sent with empty “payload”.

At the bottom of the plugin UI, the current status is displayed.

When a simulation is running, the “Pause” button will temporary stop RTCM3 message transmission to observe position solution degradation on the rover over time.

## 5. Running simulations

Start two instances of the Skydel application. Select the previously saved configuration for the rover in one instance, and previously saved configuration for the base station in another instance.

Start the simulation in the rover instance. Due to simulators synchronization, the base station instance should start automatically.

## 6. Appendix A – Receiver configuration

Receiver configuration procedures will significantly vary depending on the receiver vendor. Here, we provide an example with U-Blox F9P receiver, controlled by the U-Blox U-Center application.

### Configuration of u-blox F9P.

Connect the receiver to a PC. Ensure the receiver’s drivers and U-center software are installed.

Connect to the receiver from the u-center software. Select menu item View->Configuration View->PRT (Ports). Press Poll to ensure the displayed configuration is up to date.

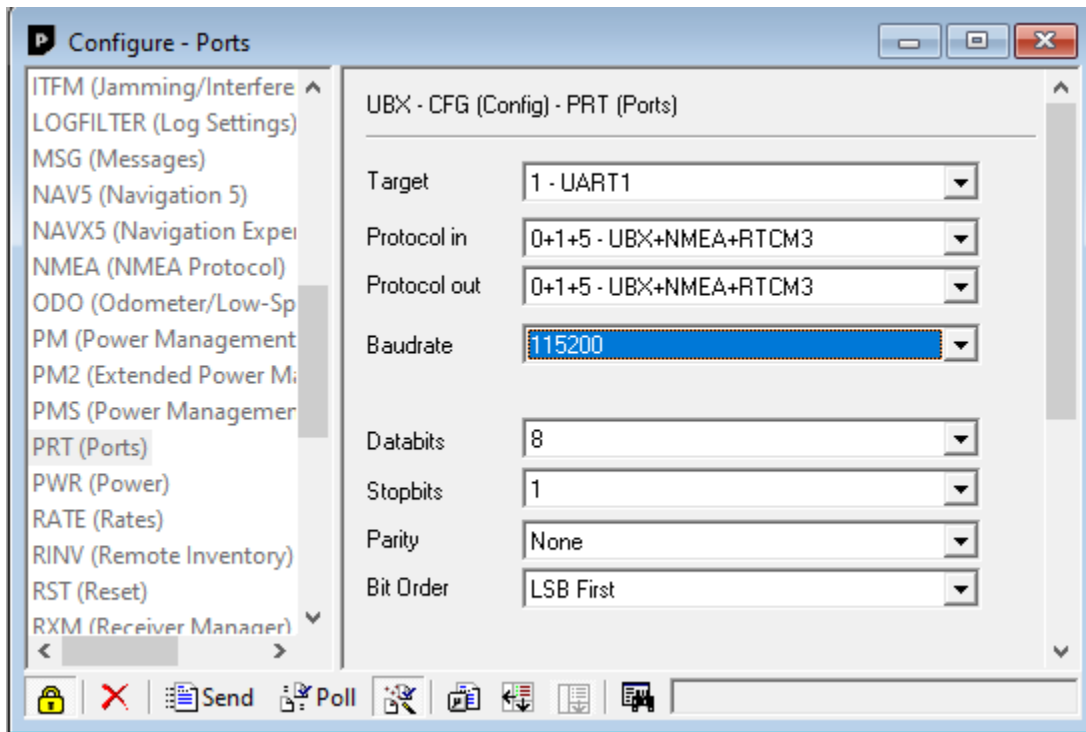

Select an item in the “Target” drop-down menu that corresponds to the interface of the receiver you want to send RTCM3 data to. Please consult the receiver or GNSS receiver module documentation to determine the correct interface. Check that the selected “Protocol in” configuration contains “RTCM3”. If it is not the case, then switch it to another option containing both “UBX” and “RTCM3”. The baudrate setting is recommended to be at least 115200. Lower baud rate is possible but keep in mind that there must be enough bandwidth to send RTCM data in real time.

Press “Send” button to send configuration to the receiver. Close the “Configuration” window. **The application may ask you to save the configuration into non-volatile memory of the receiver.**

## 7. Contact

Should you have any questions or comments please visit the following link, where you can request product information or technical assistance:

[www.orolia.com/support/testing-simulation](http://www.orolia.com/support/testing-simulation)

You can also email Technical Support directly at:

[simulationsupport@orolia.com](mailto:simulationsupport@orolia.com)

*- End of document -*