

Interconnecting any GPS Engine & Spectratime Smart SRO Rubidium SynClock+® Engine

Interconnecting any GPS Engine & Spectratime Smart SRO-100 Rubidium SynClock+® Engine for Seamless OEM System Integration



Contents	
Introduction.....	1
Simple Interconnection Schematic.....	2
Smart Interconnection Schematic.....	3

Introduction

At power on or after a Reset, the SRO SynClock+® engine is able to send out on the serial communication port some commands to configure a GPS receiver.
 This document shows the 2 basic connectivity schematics. To monitor the GPS or SynClock+® a serial connection with a PC is included. This is only needed for initial tuning. Once it's done, this connection is no longer needed. Thus it is possible to build up an autonomous GPS tracking system.
 Please note that to make the SynClock+® tests simple, it is more efficient to order a GDK (GPS SynClock+® Designer Kit) at SpectraTime.

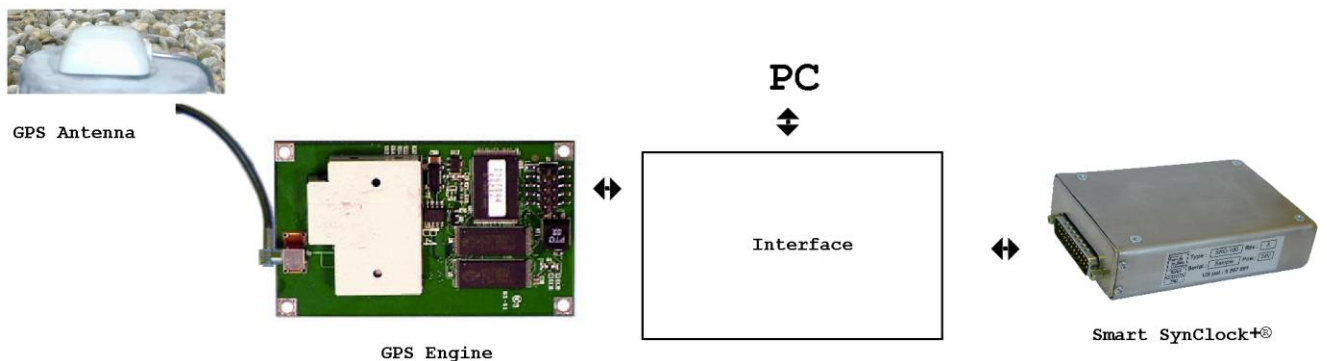

Figure 1 – GPS, SynClock+® & PC Interconnection

Simple Interconnection Schematic

Figure 2 illustrates the PC interconnection interface, which allows communication to the Smart SynClock+®, but not to the GPS. After the power on or after a reset, the SynClock+® can send out some commands to configure the GPS receiver. The pin diagram of the GPS connector showed below corresponds to Motorola OnCore and Navman Jupiter products. For the SynClock+® software setup, please refer to the GDK-1 Designer Kit User Manual on the SpectraTime website.

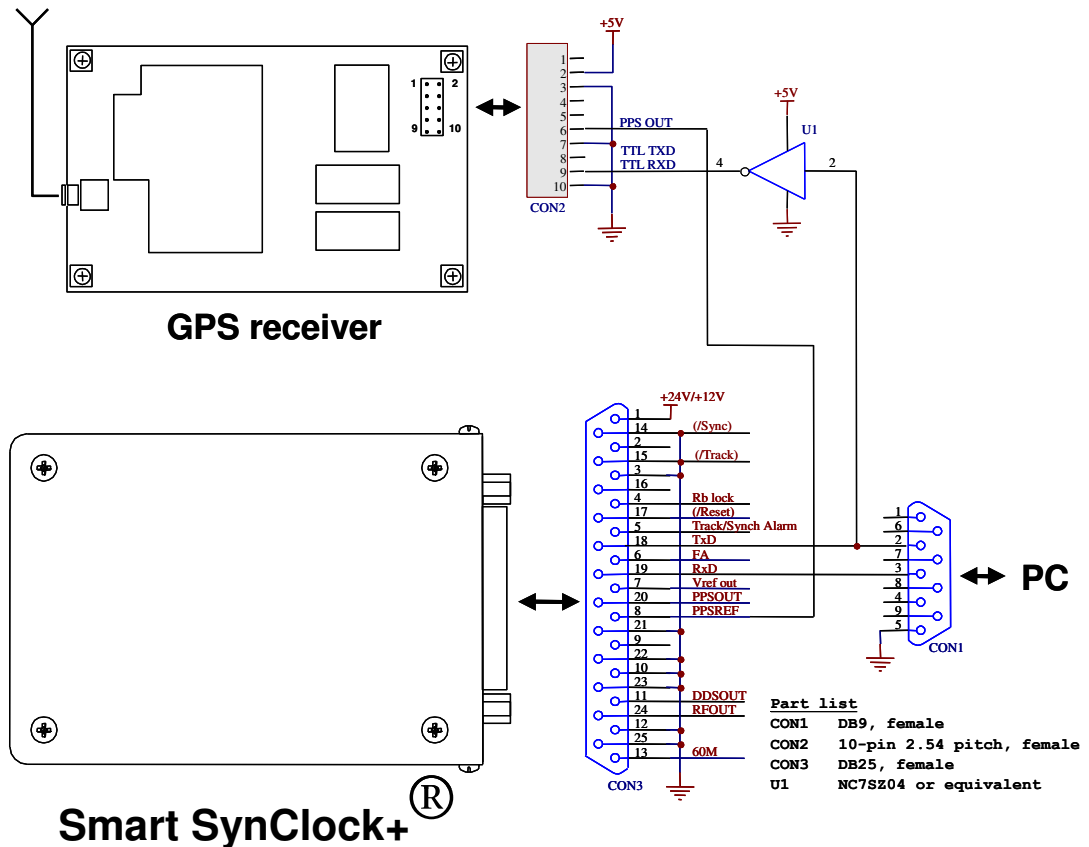

Figure 2 – Simple GPS, SRO SynClock & PC Interface

Smart Interconnection Schematic

Figure 3 illustrates the PC interconnection interface, which allows communication to both the Smart SynClock+® and the GPS. After the power on or after a reset, the SynClock+® can send out some commands to configure a GPS receiver. The pin diagram of the GPS connector showed below corresponds to Motorola OnCore and Navman Jupiter products. For the SynClock+® software setup, please refer to the GDK-1 Designer Kit User Manual on the SpectraTime website. To monitor the GPS receiver, a software program is provided by the GPS vendor, if needed.

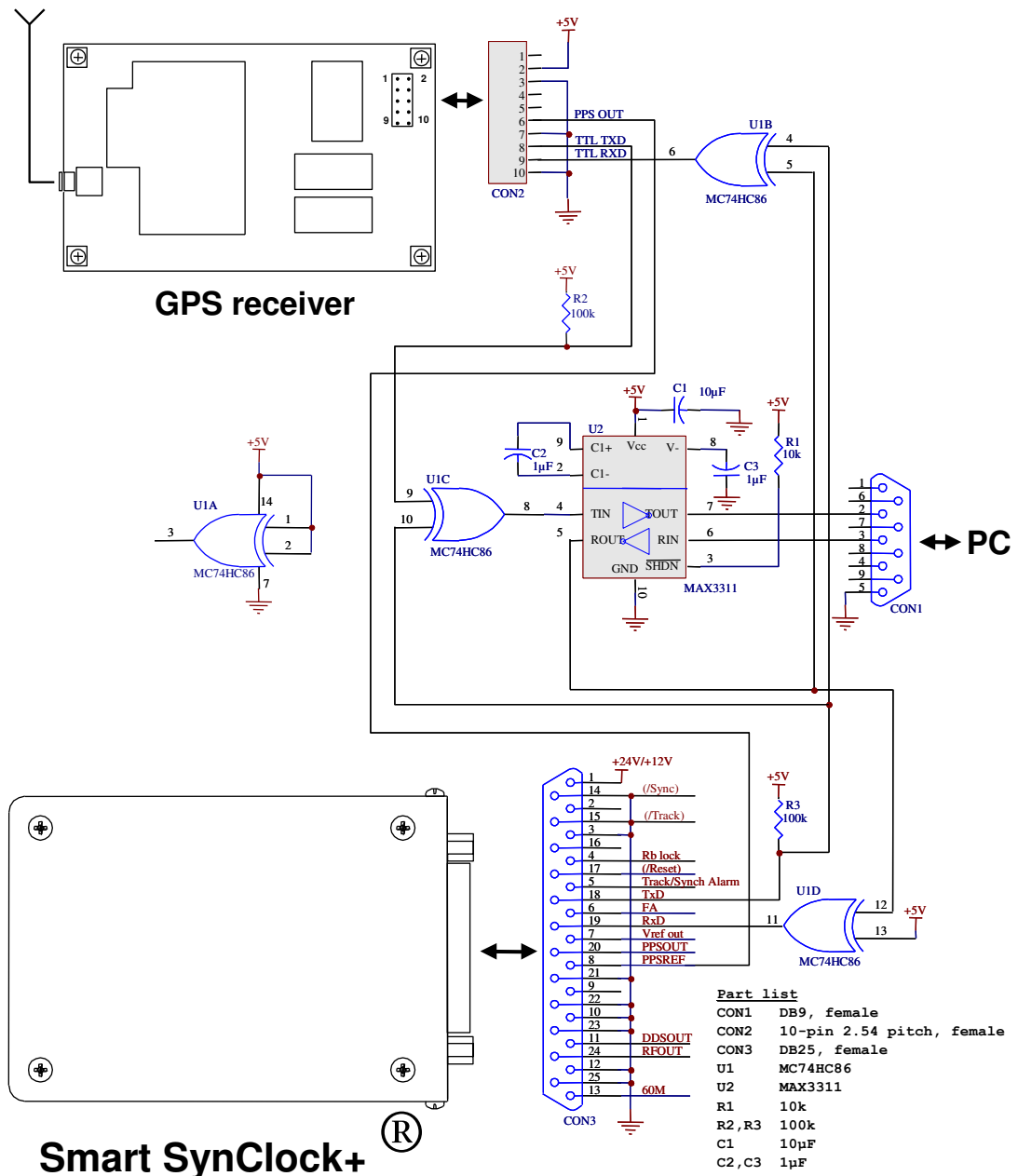

Figure 2 – Simple GPS, SRO SynClock & PC Interface