

## Technical Note: SecureSync

# Troubleshooting GPS/Glonass reception issues with the Spectracom SecureSync

**Purpose:** The purpose of this document is to provide detailed information on troubleshooting GPS reception-related issues with Spectracom SecureSync.

Spectracom SecureSyncs can be purchased with an internal GPS receiver (prior to ~ April 2014) or GNSS receiver (starting ~ April 2014) that allows GPS (and with a GNSS receiver installed, optionally Glonass as well) to be a primary input reference for synchronization. When using GPS/Glonass as an input reference, there are a few factors that can inhibit reception in the Spectracom SecureSync. Satellite reception problems can be caused by faulty antenna cable connections or by the type of antenna cable in use. They may also be a result of the overall length of the antenna cable. Other potential causes of reception issues include the physical position of the antenna and proximity to local sources of interference. This Tech Note is intended to assist Spectracom customers in troubleshooting issues concerning satellite reception.

If your installation includes either a Spectracom Model 8228 window-mount GPS antenna, or Models 8230 or 8225 outdoor antenna placed in a window, initially skip Sections 1 and 2 of this document and refer first to Section 4.

**Note:** Archive software version 5.1.2 introduced a new design of the web browser interface. Section 1 discusses Archive software versions 5.1.2 and above for the newer web browser interface, while Section 2 discusses Archive software versions 5.0.2 and below with the classic interface web browser.

## TABLE OF CONTENTS

Section 1: Identifying a GPS Reception Issue exists (Software versions 5.1.2 and above) .....	2
Section 2: Identifying a GPS satellite reception issue exists (Archive versions 5.0.2 and below with the “classic interface” web browser) .....	10
Section 3: Troubleshooting a GPS Reception Issue .....	18
Process A: Troubleshooting Opens or Shorts in the Antenna Cable.....	19
Process B: Troubleshooting Cable “OK” Related Issues.....	27
Specific to only SecureSyncs with a SAASM GPS receiver installed (note this GPS receiver is only available to qualified US Military/DOD/NATO organizations).....	29
Section 4: Using a Model 8228 Window-Mount Antenna with SecureSync .....	31
Spectracom Technical Support.....	34

## Section 1: Identifying a GPS Reception Issue exists (Software versions 5.1.2 and above)

After initially connecting the GPS antenna to the SecureSync (with it powered up and running), the front panel Fault light should not be blinking amber/red (Blinking amber indicates the GPS antenna is not yet connected or an open/short is present in the antenna cable- Refer to [Process A](#) if the Fault LED is blinking red).

About 33-35 minutes after the SecureSync has begun to track at least 4 satellites, the GPS survey will be completed and the Sync lamp on the front panel should indicate uninterrupted green. The Sync light should remain uninterrupted green thereafter, unless the SecureSync is power-cycled or the GPS/GNSS antenna is disconnected.

If the Sync lamp does not indicate uninterrupted green after about 40 minutes with the unit initially powered up and the antenna connected, the SecureSync may not be receiving signal from the minimum number of four satellites necessary to declare initial time sync. If the front panel Sync light initially indicates uninterrupted green but periodically turns amber anytime thereafter, the SecureSync may be experiencing intermittent reception issues (with no other reference inputs available). This condition indicates GPS/Glonass reception issues that need to be investigated.

### Reference Priority table

In order for SecureSync to be able to synchronize to GPS and/or Glonass satellites, "GNSS 0" needs to be listed and enabled in the Reference Priority Setup table ("GNSS 0" is listed and enabled by factory default, if a GNSS receiver which can track GPS and/or Glonass satellites is installed). To verify "GNSS 0" is enabled, navigate to the **Management -> Reference Priority** page of the web browser. The Reference Priority Setup table should display "GNSS 0" in one row of the table (in both the "Time" and "PPS" columns) and the corresponding "Enabled" field in that row should be selected.

Priority	Time	1PPS	Enabled	Action
1	GNSS 0	GNSS 0	<input checked="" type="checkbox"/>	Delete
2	NTP 1	GNSS 0	<input checked="" type="checkbox"/>	Delete
3	GNSS 0	GNSS 0	<input type="checkbox"/>	Delete
4	NTP 1	NTP 1	<input type="checkbox"/>	Delete
5	User 0	User 0	<input type="checkbox"/>	Delete

Make sure that one row of the table contains "GNSS 0" in both the "Time" and "1PPS" column and this row is "Enabled"

Figure 1: Reference Priority Setup table

### Reference Status table

One indication of a GPS/Glonass reception problem occurring is displayed in the “Reference Status” table in the **Home** page of the browser (upper-right hand corner of the browser). If satellite reception is fully qualified, both circles in the “GNSS 0” row will be green (neither will be red).

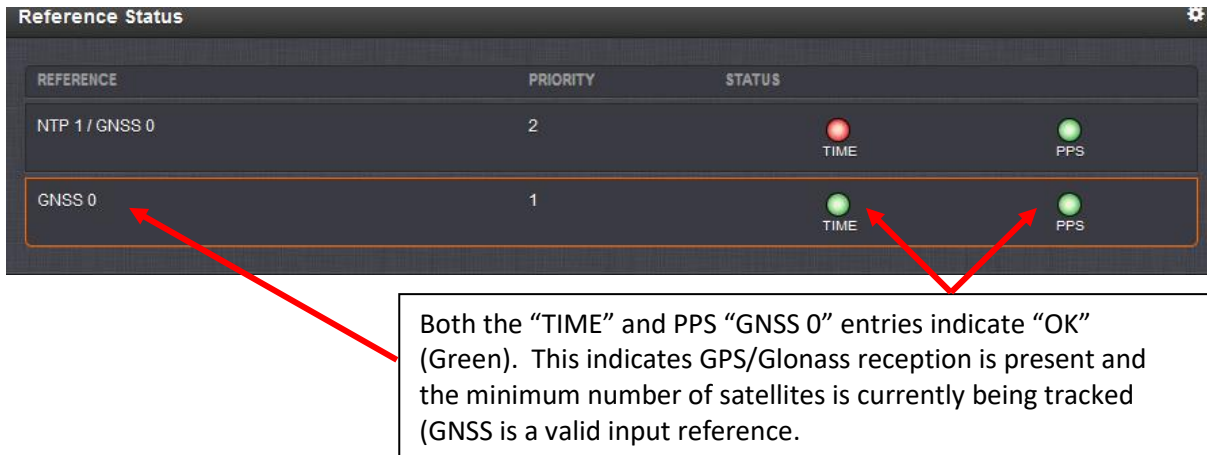

**Figure 2: Input Reference Status page with GPS reception present and valid**

The “Reference Status” table displays information on all available input “Time” and “PPS” input references, including whether the input is enabled or not (per the “Enabled” field), and whether or not the input is present and considered valid (per the Time and PPS indicators). Reference inputs that are present and considered valid are displayed with a Green circle (while input references that are either not present or not considered valid are displayed as a Red circle).

In the examples shown in Figures 2 and 3, “GNSS 0” (representing GPS/Glonass input and indicated as “GNSS 0” in both the “Time” and “PPS” columns) is an “Enabled” reference input. Because both the “Time” and “PPS” boxes for GPS are shown as Green circles (Figure 2) , GPS and/or Glonass reception is both currently present and considered valid (the GNSS receiver is currently tracking at least the minimum number of satellites needed for it to be considered a valid “Time” and “1PPS” reference).

If the GPS/GNSS receiver starts to track less than the minimum number of GPS and/or Glonass satellites (or no satellites at all), both of the “Time” and “PPS boxes” for “GNSS 0” will go into the ALARM state (red circles) as shown in the Figure below:



**Figure 3: Input Reference Status page with GPS reception either not present or invalid**

The most obvious indication that there is a problem with GPS and/or Glonass reception, because of an antenna cable issue, is that the front panel Fault light will blink amber, if any opens or shorts are detected in the antenna cable. If this occurs with the SecureSync connected to a GPS antenna, a cable issue exists; refer to [Process A](#). However, if a GPS splitter is being used to allow a GPS antenna to be shared by more than one SecureSync or other Spectracom NetClocks, this may be a normal indication caused by the splitter (depending on whether the DC-blocked port simulates the normal current draw of a GPS antenna using a load resistor).

The SecureSync’s Web Browser User Interface (Web UI) can be used to determine if the Time Server is currently tracking any satellites. Once the GPS antenna is connected and the unit is powered up, the unit should be tracking at

least four satellites within 20 minutes. If it is not tracking at least four satellites with the antenna installed outdoors, it is likely there is a reception-related issue.

The first step is to determine if the unit is not currently tracking any GPS and/or Glonass satellites at all. Or, if it is able to track satellites, but it is tracking less than the four required satellites for the survey to be performed.

To determine the number of satellites currently being tracked, log in to the SecureSync’s Web UI. The **Interfaces** -> **GNSS** page of the browser reports the number of satellites being tracked.

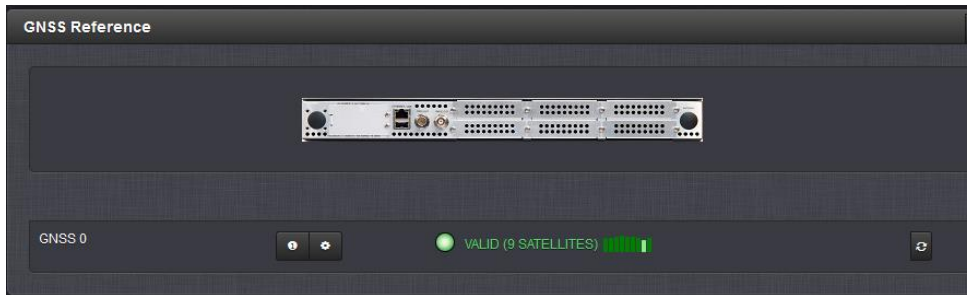
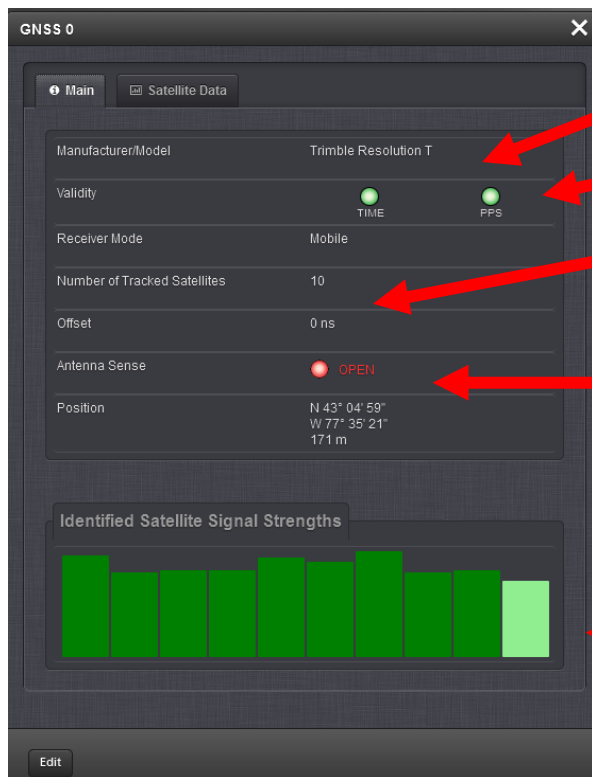

Figure 4: GNSS Signal Status view

For a detailed view, from this page, click on the “circled i” ICON in the bottom row, under the photo. Or from the main menu, click on “**Interfaces**” at the top of the page and in the drop-down, select “**GNSS 0**”. The “**Main**” tab should be automatically selected (as shown below):



- GPS or GNSS receiver Model installed.
- This line indicates the validity of the GNSS receivers Time and PPS inputs.
- This line indicates the number of combined GPS and/or Glonass satellites currently being used for time/position fix information.
- This line indicates whether an open or short is being detected in the antenna cable (“OK” indicates no cable issues are being detected at this moment). In this example, an open in the cable is being detected.
- Mouse-hover over each of the bar graphs to indicate the satellite ID numbers being used in the fix and their relative signal strengths (SNR values) for those particular satellites.

Figure 5: GNSS Signal Status view

As shown in Figure 5, the “GNSS 0 Input Status” page will indicate the current number of GPS and/or Glonass satellites being used in the positional fix (based on the number of vertical bars being displayed). If this field indicates no bars, it is currently not tracking any satellites. If this field indicates a low number of bars, such as only “1”, “2” or “3”, the unit is tracking a few satellites, but it’s not tracking the minimum number of satellites required for initial sync.

**Distinguishing between GPS satellites and Glonass satellites, when the Glonass Option is enabled**

To determine if each bar represents a GPS or a Glonass satellite, Mouse-hover each bar to see a report of three values (two letters, the Satellite ID number and the signal strength value for that satellite).

- GPS satellites are indicated with the two letters of “GP” and have a Satellite ID Number of **0 to 59**
- Glonass satellites are indicated with the two letters of “GL” and have a Satellite ID Number of **60 and above**

Tracking a low number of satellites (but not zero satellites) rules out shorts or opens occurring in the antenna cable and typically indicates that the antenna’s view of the horizon/sky is obstructed. Once the GPS survey has initially been completed, the minimum number of satellites drops to just one satellite required from that point forward, even if the time server is subsequently power cycled.

Also included in the GNSS 0 Status page is an “Antenna Sense” indication. The GNSS receiver can detect opens or shorts occurring in the antenna cable. Antenna Sense showing “OK” indicates that the antenna is connected with no opens or short in the cable are being detected at this moment (an intermittent antenna cable issue may not be displayed here, but will be captured in the Event log). Below is an indication that the GNSS receiver is currently detecting an open in the antenna cable.

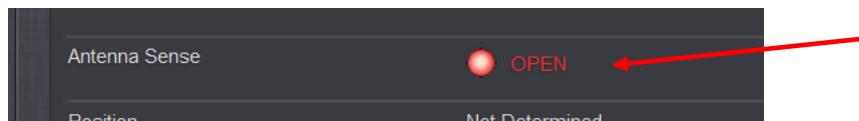

**Figure 6: Identified Antenna Sense indicating an Open in the antenna cable**

The “Identified Satellite Signal Strengths” table (also displayed on the bottom of this web page) indicates the specific satellite ID number (“ID”) that each of the 12 channels is assigned to track and the relative signal strength (“SNR”) of the received signal (greater than about 37 indicates usable signal strength). Mouse-hover over each column to see these values.

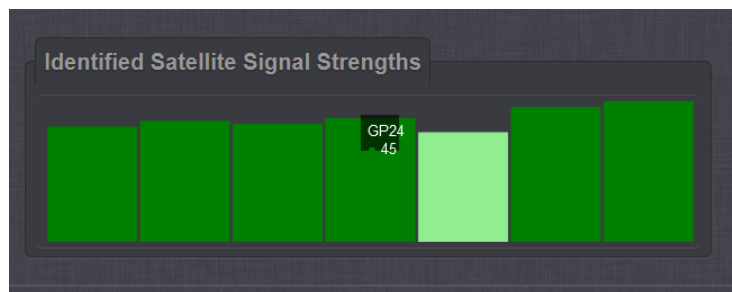

**Figure 7: Identified Satellite Signal Strengths Columns**

In the example shown in Figure 7, seven satellites are currently being tracked (there are 7 vertical bars displayed). The satellites ID numbers are obtained by hovering over each green bar. In this particular example, the fourth bar indicates it represents GPS satellite ID Number 24 with a received signal strength of 45. Light green bars indicates marginal signal strengths while darker green bars indicate stronger signals.

### Alarms Log

A second indication of GPS reception issues is based on entries contained in the “Alarms” log. The Alarms Log contains a list of any minor or major alarms that have been asserted, such as “Not In Sync” and “GPS Antenna Problem” alarms (if the Antenna Sense circuit detected any shorts or opens in the antenna cable). To view the Alarms Log, navigate to this page by clicking on “Tools” on the top of the main page and then on “Alarms” in the dropdown. Refer to Figure 8.

The screenshot shows the 'alarms Log' interface with a search bar and a table of log entries. The table has columns for Id, Date, Entity, and Message. A red arrow points to the entry with Id 68, which has the message 'GPS Antenna Problem'. A callout box next to it states: '“GPS Antenna Problem” indicates the antenna sense circuit has detected that a short or open exists in the antenna cabling.'

Id	Date	Entity	Message
71	Feb 17 23:32:01	[system]	~~~~~
70	Feb 17 23:32:01	[system]	STATUS CHANGE:
69	Feb 17 23:32:01	[system]	ACTIVE ALARMS: MINOR
68	Feb 17 23:32:01	[system]	GPS Antenna Problem
67	Feb 17 23:25:40	[system]	~~~~~
66	Feb 17 23:25:40	[system]	STATUS CHANGE:
65	Feb 17 23:25:40	[system]	ACTIVE ALARMS: MAJOR MINOR
64	Feb 17 23:25:40	[system]	GPS Antenna Problem
63	Feb 17 23:25:40	[system]	Frequency Error
62	Feb 14 22:42:43	[system]	~~~~~

Navigation controls: First Previous 1 2 3 4 5 Next Last

Figure 8: Alarms Log Entries

## Events Log

A third indication of GPS reception issues is based on entries contained in the “Events” log. The Events Log contains a list of event changes, such as loss of time sync and Antenna Problem alarms being asserted (if the Antenna Sense circuit detected any shorts or opens in the antenna cable). To view the Events Log, navigate to this page by clicking on “Tools” on the top of the main page and then on “Events” in the dropdown. Refer to Figure 9.

Example entries that may be reported include:

- A) **“GPS Antenna Problem”** indicates the antenna sense circuit has detected that a short or open exists in the antenna cabling.
- B) **“Too few GPS Sat”** indicates not enough satellites are currently being tracked.
- C) **“In Holdover”** indicates SecureSync was in Sync, but has since lost all external references and is now using the internal oscillator to derive the time. Outputs are still useable.
- D) **“No longer In Holdover”** indicates either the Holdover period has expired, or GPS reception has been restored.
- E) **“Not in Sync”** indicates no references are available and the holdover period has since expired. Outputs may not be useable.

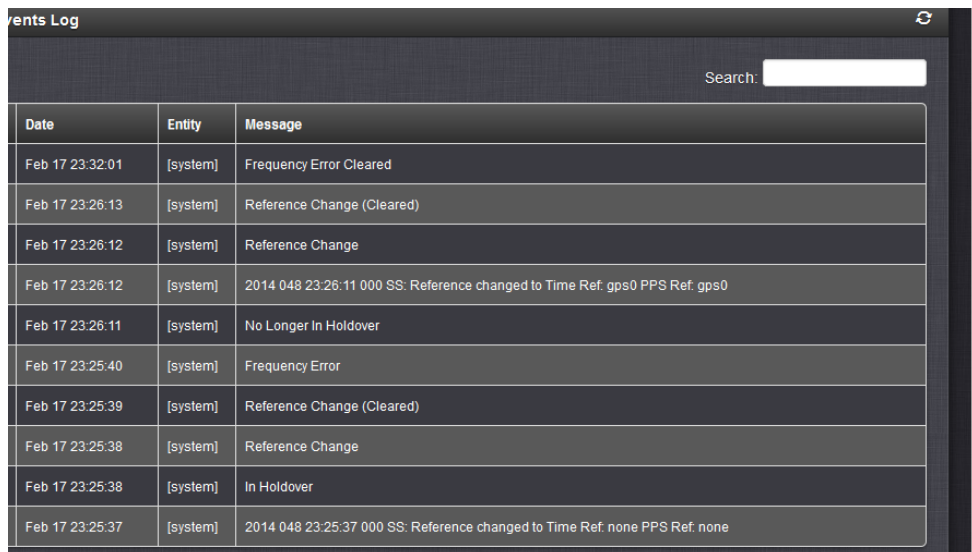

Date	Entity	Message
Feb 17 23:32:01	[system]	Frequency Error Cleared
Feb 17 23:26:13	[system]	Reference Change (Cleared)
Feb 17 23:26:12	[system]	Reference Change
Feb 17 23:26:12	[system]	2014 048 23:26:11 000 SS: Reference changed to Time Ref. gps0 PPS Ref. gps0
Feb 17 23:26:11	[system]	No Longer In Holdover
Feb 17 23:25:40	[system]	Frequency Error
Feb 17 23:25:39	[system]	Reference Change (Cleared)
Feb 17 23:25:38	[system]	Reference Change
Feb 17 23:25:38	[system]	In Holdover
Feb 17 23:25:37	[system]	2014 048 23:25:37 000 SS: Reference changed to Time Ref. none PPS Ref. none

**Figure 9: Example Event Log Entries**

If the SecureSync has intermittent GPS/Glonass satellite reception issues that are causing all satellite reception to cease, the Events Log may display “In Holdover” alarms and/or time synchronization alarms. “In Holdover” alarms indicate the SecureSync appliance is no longer tracking any satellites (and has no other external reference available), but has not yet declared the loss of Time Sync (the time is being derived from the built-in oscillator and the SecureSync is still a useable time reference). Time Sync alarms indicate the SecureSync is no longer synchronized and external devices are likely ignoring the SecureSync as a reference. “Antenna Problem” alarms in this log indicate an opens or short in the antenna cable is likely present (or the GPS/GNSS antenna is not connected to SecureSync).

If both Holdover/Time Synchronization alarms and “Antenna Problem” alarms are present, the likely cause of the loss of satellite reception is due to an antenna cable issue. If Holdover/Time Sync alarms are present, but Antenna Problem alarms are not present, the satellite reception issue is unlikely to be due to shorts or opens in the antenna cable (unless the Antenna Sense circuit has been damaged by a surge/lightning).

### Qualification Log

A third indication of GPS reception issues is based on entries contained in the “Qualification” log. This log contains a running hourly count of the number of GPS and/or Glonass satellites tracked each hour. This history data can be used to determine if a satellite reception problem exists and whether this is a continuous or intermittent reception issue. To view the GPS Qualification Log, navigate to this page by clicking on “Tools” on the top of the main page and then click on the “Qualification”.

GNSS satellite reception may be displayed as cyclic in nature. A cyclic 12 hour pattern of decreased satellite reception typically indicates that the GNSS antenna has an obstructed view of the horizon. GPS satellites are in a 12-hour orbit, so if part of the sky is blocked by large obstructions, at the same time every day (at approximately 12 hour intervals), the GPS reception may be reduced or may vanish altogether. If this occurs, the antenna should be relocated to afford it an unobstructed view of the sky.

Every hour (displayed in the log as UTC time), SecureSync counts the total number of satellites that were tracked during that hour. The Qualification log shows the number of satellites that were tracked followed by the number of seconds that the particular number of satellites were tracked during the hour (3600 seconds indicates a full hour). The number to the left of the “=” sign indicates the number of satellites tracked and the number to the right of the “=” sign indicates the number of seconds (out of a total of 3600 seconds in an hour) that the unit was tracking that number of satellites. For example, “0=3600” indicates the unit was tracking 0 satellites for the entire hour, while “0=2700 1=900” indicates the unit was tracking one satellite for 900 seconds, but for the remaining portion of the hour it was tracking zero satellites.

Every hourly entry in the log also contains a quality value, represented by “Q= xxxx” (where x can be any number from 0000 through 3600). If SecureSync tracked at least four satellites for the entire hour in the standard mode or at least one satellite for the entire hour in Single Satellite Mode, the Quality value will equal 3600. For every second SecureSync tracked less than the minimum number of satellites, the value will be less than 3600. The minimum requirement is one satellite at all times after the unit has completed the GPS survey and indicates “Stationary”. A minimum of four satellites are required in order for the GPS survey to be initially completed.

If all entries in the Qualification log are displayed as “0=3600”, a constant GPS reception problem exists, so the cause of the reception issue is continuous. If the unit occasionally shows 0=3600 but at other times shows that 1 through 12 have numbers of other than “0000”, the reception is intermittent, so the cause of the reception issue is intermittent. If the Quality value normally equals 3600 but drops to lower than 3600 about every 12 hours, the issue is likely caused by the GPS antenna having an obstructed view of the sky.

### Example GPS Qualification Log entry:

Id	Date	Entity	Message
503	Feb 17 23:00:02	[system]	GPS 0: 5 = 60 6 = 528 7 = 887 8 = 2125 Q = 3600

Figure 10: Example GPS Qualification Log Entries

In this example entry, SecureSync tracked no less than 5 satellites for the entire hour. Out of the entire hour, it was tracking 5 satellites for a cumulative total of 60 seconds (not necessarily in a row). For the duration of the hour, it was tracking 7 and 8 satellites for a period of time. Because it was tracking at least one satellite for the entire hour, this Quality value is Q=3600.

**Note:** If SecureSync is not connected to a GNSS antenna (or is never able to start tracking any satellites at all), the Qualification log will remain empty.

### Timing Log

When a Rubidium oscillator is installed in the SecureSync, a fourth indication of a GPS reception issue occurring is the presence of “**Rb track off – free run**” and “**RB synchronized**” log entries in the Timing log. To view the GPS Timing Log, navigate to this page by clicking on “**Tools**” on the top of the main page and then click on the “**Timing**”.

When there are no 1PPS input references present or considered valid (such as the GPS receiver is no longer able to track at least four satellites), it is not desired to discipline the oscillator to a potentially unstable 1PPS input reference. To prevent this from happening, when there are no valid 1PPS input references available to SecureSync, the Rubidium oscillator is automatically placed into a free run state where it is not locked/steered to any 1PPS input references.

When the oscillator is placed into a free run state, the “**Rb track off -- free run**” entry is asserted in this log. Once a valid 1PPS input reference has become available again (such as the GPS receiver is once again tracking at least four satellites, for example), the “**RB synchronized**” log entry is asserted into this log. This indicates the oscillator is now locked and being disciplined to the highest priority input reference that is available to SecureSync.

The Timing log will also report if there are any opens or shorts occurring in the GPS antenna cable, as indicated by “**GPS Antenna**” entries being asserted into this log.

## Section 2: Identifying a GPS satellite reception issue exists (Archive versions 5.0.2 and below with the “classic interface” web browser)

After initially connecting the GPS antenna to the SecureSync (with it powered up and running), the front panel Fault light should not be blinking amber/red (Blinking amber indicates the GPS antenna is not yet connected or an open/short is present in the antenna cable- Refer to [Process A](#) if the Fault LED is blinking red).

About 33-35 minutes after the SecureSync has begun to track at least 4 satellites, the GPS survey will be completed and the Sync lamp on the front panel should indicate uninterrupted green. The Sync light should remain uninterrupted green thereafter, unless the SecureSync is power-cycled or the GPS antenna is disconnected.

**Note:** The percentage of the GPS survey that has been completed thus far can be viewed in the “Survey Prog” field located on the **Status -> Inputs -> GPS** page of the web browser. 50% complete indicates the survey will be completed in about 17 minutes (100% is about 34 minutes). Once the GPS survey has been completed, “Stationary” will be displayed from that point forward (even if the unit is subsequently power cycled).

If the Sync lamp does not indicate uninterrupted green after about 40 minutes with the unit initially powered up and the GPS antenna connected, the SecureSync may not be receiving signal from the minimum number of four satellites necessary to declare initial time sync. If the front panel Sync light initially indicates uninterrupted green but periodically turns amber anytime thereafter, the SecureSync may be experiencing intermittent GPS reception issues (with no other reference inputs available). This condition indicates GPS reception issues that need to be investigated.

### Reference Priority table

In order for SecureSync to be able to synchronize to GPS, “GPS 0” needs to be listed and enabled in the Reference Priority Setup table (“GPS 0” is listed and enabled by factory default, if a GPS receiver is installed). To verify “GPS 0” is enabled, navigate to the **Setup -> Reference Priority** page of the web browser. The Reference Priority Setup table should display “GPS 0” in one row of the table (in both the “Time” and “1PPS” columns) and corresponding “State” value in that row should indicate “Enabled”.

Index	State	Priority	Time	1PPS	Delete
0	Enabled	1	GPS 0	GPS 0	<input checked="" type="checkbox"/>
1	Enabled	2	IRIG 0	IRIG 0	<input type="checkbox"/>
2	Enabled	3	NTP	NTP	<input type="checkbox"/>
3	Enabled	4	User	User	<input type="checkbox"/>

Make sure that one row of the table contains “GPS 0” in both the “Time” and “1PPS” columns.

Figure 11: Reference Priority Setup table

### Reference Status table

One indication of a GPS reception problem occurring is displayed in the Reference Status table on the **Status -> Time and Frequency** page of the browser.

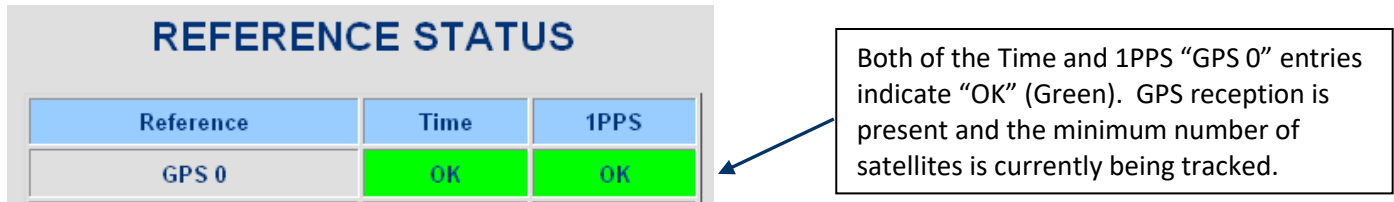

Figure 12: Input Reference Status page with GPS reception present and valid

The Reference Status table displays information on all available input “Time” and “1PPS” input references, including whether the input is enabled or not (per the “State” field), and whether or not the input is present and considered valid (per the State and 1PPS fields). Reference inputs that are present and considered valid are displayed with “OK” (Green) while input references that are either not present or not considered valid are displayed as either “ALARM” (Red) or as “Not Valid” (Orange), depending upon the installed version of software (software version 4.4.0 and above displays an orange fill with “Not Valid” indicated).

In the examples shown in Figure 11 and Figure 12, “GPS 0” (representing GPS input and indicated as “GPS 0” in both the “Time” and “1PPS columns”) is an “Enabled” reference input. Because both the “Time” and “1PPS” boxes for GPS are shown as “OK” (Green), GPS reception is both currently present and considered valid (the GPS receiver is currently tracking at least the minimum number of satellites needed for it to be considered a valid “Time” and “1PPS” reference).

If the GPS receiver starts to track less than the minimum number of satellites (or no satellites at all), both of the “Time” and “1PPS boxes” for “GPS 0” will go into the ALARM state (red or orange, depending on the installed software version), as shown in Figure 13.

**Note:** In software versions 4.4.0 and above, if the GPS receiver starts to track less than the minimum number of satellites (or no satellites at all), both of the Time and 1PPS boxes for “gps0” will go into the “Not Valid” state (orange fill), as shown in Figure 14.

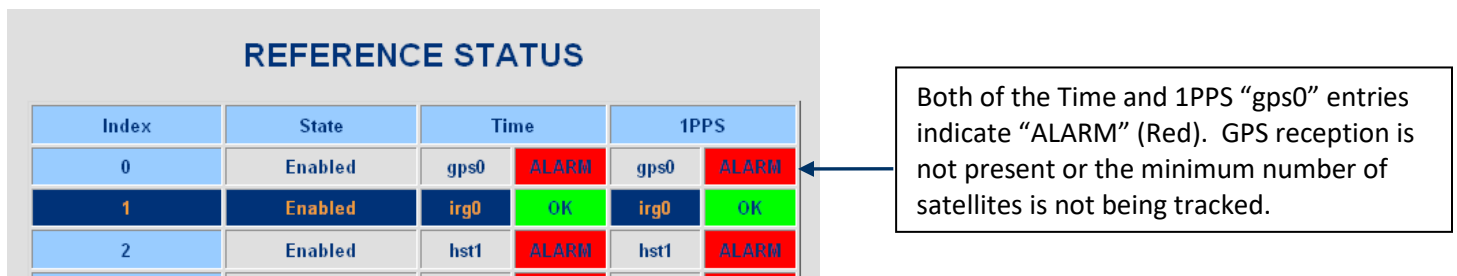

Figure 13: Input Reference Status page with GPS reception either not present or invalid

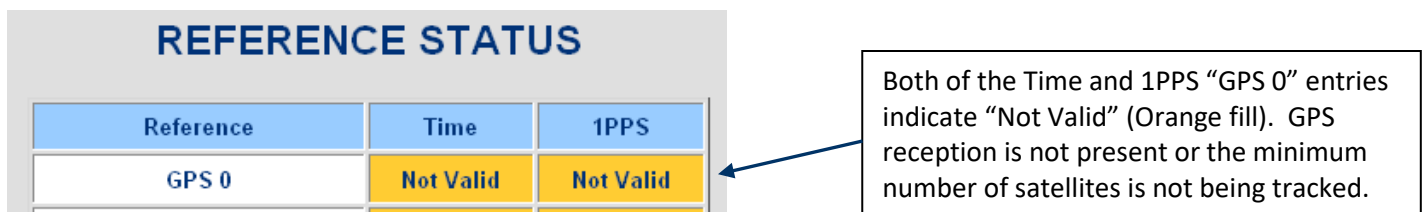

Figure 14: Input Reference Status page with GPS reception either not present or invalid

The most obvious indication that there is a problem with GPS reception, because of an antenna cable issue, is that the front panel Fault light will blink amber, if any opens or shorts are detected in the antenna cable. If this occurs with the SecureSync connected to a GPS antenna, a cable issue exists; refer to [Process A](#). However, if a GPS splitter is being used to allow a GPS antenna to be shared by more than one SecureSync or other Spectracom NetClocks, this may be a normal indication caused by the splitter (depending on whether the DC-blocked port simulates the normal current draw of a GPS antenna using a load resistor).

**Note:** If any Major alarms are also asserted while the Antenna Problem alarm is asserted, the Fault LED will be lit solid and will not blink, unless all Major alarms are extinguished.

The SecureSync Web Browser User Interface (Web UI) can be used to determine if the Time Server is currently tracking any satellites. Once the GPS antenna is connected and the unit is powered up, the unit should be tracking at least four satellites within 20 minutes. If it is not tracking at least four satellites with the antenna installed outdoors, it is likely there is a reception-related issue.

The first step is to determine if the unit is not currently tracking any GPS satellites at all. Or, if it is able to track satellites, but it is tracking less than the four required satellites for the GPS survey to be performed. To determine the number of satellites currently being tracked, log in to the SecureSync’s Web UI. Click on **“Status”** at the top of the page and in the drop-down, select **“Inputs”**. Then click on **“On-Board Reference GPS”** (located in the blue box).

### GPS INPUT STATUS

Manufacturer/Model	Trimble Resolution T
1PPS Validity	OK
Time Validity	OK
Receiver Mode	Standard
Dynamic Mode	Stationary
GPS Longitude	077° 38' 42.958" W
GPS Latitude	043° 03' 50.832" N
GPS Altitude	177.022 m
Survey Prog	Complete
Number of Tracked Satellites	9
Offset	0 nsec
Antenna Sense	OK

ID	3	6	7	13	16	19	23	8	24	0	0	0
SNR	44	44	46	46	43	44	46	38	37	0	0	0

This line indicates the number of satellites currently being used for time/position fix information.

This line indicates whether an open or short is being detected in the antenna cable (“OK” indicates no cable issues are being detected at this moment).

This table indicates the satellite ID numbers being used in the fix and their relative signal strengths (SNR values) for those satellites.

**Figure 15: GPS Signal Status Page**

As shown in Figure 15, the “GPS Input Status” page will indicate the current number of satellites being used in the positional fix (located just above the table of received satellite data at the bottom of the page). If this field indicates “0”, it is currently not tracking any satellites. If this field indicates a low number of satellites, such as “1”, “2” or “3”, the unit is tracking a few satellites, but it’s not tracking the minimum number of satellites required for initial GPS operation.

Tracking a low number of satellites (but not zero satellites) rules out shorts or opens occurring in the antenna cable and typically indicates that the antenna’s view of the horizon/sky is obstructed. Once the GPS survey has initially been completed (as indicated by the **Status / Inputs/ GPS** page showing the “Survey Prog” as “Stationary”), the minimum number of satellites drops to just one satellite required from that point forward, even if the appliance is power cycled thereafter.

Also included in the GPS Input Status page is an “Antenna Sense” indication. The GPS receiver can detect opens or shorts occurring in the GPS antenna cable. Antenna Sense showing “OK” indicates that the GPS antenna is connected with no opens or short in the cable are being detected at this moment (an intermittent antenna cable issue may not be displayed here, but will be captured in the Event log).

The ID/SNR table (also displayed on the bottom of this web page) indicates the specific satellite ID number (“ID”) that each of the 12 channels is assigned to track and the relative signal strength (“SNR”) of the received signal (greater than about 35 to 40 indicates good signal strength). The “SNR” values will be zeroes when the particular channel is not tracking any satellites.

ID	9	22	15	21	14	18	24	26	27	0	0	0
SNR	47	45	42	45	45	45	45	45	43	0	0	0

**Figure 16: ID/SNR table for GPS satellite signal strengths**

In the example shown in Figure 16, nine satellites are currently being tracked (As indicated by the first nine fields of the horizontal “SNR” column have numbers other than “0” present). The satellites ID numbers being tracked are the first nine numbers in the horizontal “ID” column and the signal strengths of these satellites (SNR horizontal column) range from 42 to 47 (Indicating good signal strengths).

### Alarms Log

A second indication of GPS reception issues is based on entries contained in the “Alarms” log. The Alarms Log contains a list of any minor or major alarms that have been asserted, such as “Not In Sync” and “GPS Antenna Problem” alarms (if the Antenna Sense circuit detected any shorts or opens in the antenna cable). To view the Alarms Log, navigate to this page by clicking on “Tools” on the top of the main page and then on “Logs” in the dropdown. Then click on the “Alarms” tab. Refer to Figure 17.

	System	Event	Alarms	Authentication	Timing	GPS
Sep 14 12:38:10	Spectracom	spectracom:	[system]	-----		
Sep 14 12:38:10	Spectracom	spectracom:	[system]	STATUS CHANGE:		
Sep 14 12:38:10	Spectracom	spectracom:	[system]	ACTIVE ALARMS: MINOR		
Sep 14 12:38:10	Spectracom	spectracom:	[system]	GPS Antenna Problem		
Sep 14 12:38:11	Spectracom	spectracom:	[system]	-----		
Sep 14 12:38:11	Spectracom	spectracom:	[system]	STATUS CHANGE:		
Sep 14 12:38:11	Spectracom	spectracom:	[system]	ACTIVE ALARMS: MAJOR MINOR		
Sep 14 12:38:11	Spectracom	spectracom:	[system]	Not In Sync		
Sep 14 12:38:11	Spectracom	spectracom:	[system]	GPS Antenna Problem		
Sep 14 12:38:12	Spectracom	spectracom:	[system]	-----		
Sep 14 12:38:12	Spectracom	spectracom:	[system]	STATUS CHANGE:		
Sep 14 12:38:12	Spectracom	spectracom:	[system]	ACTIVE ALARMS: MAJOR MINOR		
Sep 14 12:38:12	Spectracom	spectracom:	[system]	Not In Sync		
Sep 14 12:38:12	Spectracom	spectracom:	[system]	Frequency Error		
Sep 14 12:38:12	Spectracom	spectracom:	[system]	GPS Antenna Problem		
Sep 14 12:46:16	Spectracom	spectracom:	[system]	-----		
Sep 14 12:46:16	Spectracom	spectracom:	[system]	STATUS CHANGE:		
Sep 14 12:46:16	Spectracom	spectracom:	[system]	ACTIVE ALARMS: MAJOR MINOR		
Sep 14 12:46:16	Spectracom	spectracom:	[system]	Frequency Error		
Sep 14 12:46:16	Spectracom	spectracom:	[system]	GPS Antenna Problem		
Sep 14 12:48:55	Spectracom	spectracom:	[system]	-----		
Sep 14 12:48:55	Spectracom	spectracom:	[system]	STATUS CHANGE:		
Sep 14 12:48:55	Spectracom	spectracom:	[system]	ACTIVE ALARMS: MINOR		
Sep 14 12:48:55	Spectracom	spectracom:	[system]	GPS Antenna Problem		
Sep 14 19:48:45	Spectracom	spectracom:	[system]	-----		
Sep 14 19:48:45	Spectracom	spectracom:	[system]	STATUS CHANGE:		
Sep 14 19:48:45	Spectracom	spectracom:	[system]	ACTIVE ALARMS: MAJOR MINOR		
Sep 14 19:48:45	Spectracom	spectracom:	[system]	Frequency Error		
Sep 14 19:48:45	Spectracom	spectracom:	[system]	GPS Antenna Problem		
Sep 14 19:49:00	Spectracom	spectracom:	[system]	-----		
Sep 14 19:49:00	Spectracom	spectracom:	[system]	STATUS CHANGE:		
Sep 14 19:49:00	Spectracom	spectracom:	[system]	ACTIVE ALARMS: MAJOR		
Sep 14 19:49:00	Spectracom	spectracom:	[system]	Frequency Error		
Sep 14 19:50:39	Spectracom	spectracom:	[system]	-----		
Sep 14 19:50:39	Spectracom	spectracom:	[system]	STATUS CHANGE:		
Sep 14 19:50:39	Spectracom	spectracom:	[system]	ACTIVE ALARMS: NONE		
Sep 16 20:10:29	Spectracom	spectracom:	[system]	-----		
Sep 16 20:10:29	Spectracom	spectracom:	[system]	STATUS CHANGE:		
Sep 16 20:10:29	Spectracom	spectracom:	[system]	ACTIVE ALARMS: MINOR		
Sep 16 20:10:29	Spectracom	spectracom:	[system]	GPS Antenna Problem		
Sep 16 20:10:36	Spectracom	spectracom:	[system]	-----		
Sep 16 20:10:36	Spectracom	spectracom:	[system]	STATUS CHANGE:		
Sep 16 20:10:36	Spectracom	spectracom:	[system]	ACTIVE ALARMS: NONE		
Sep 16 20:10:37	Spectracom	spectracom:	[system]	-----		
Sep 16 20:10:37	Spectracom	spectracom:	[system]	STATUS CHANGE:		
Sep 16 20:10:37	Spectracom	spectracom:	[system]	ACTIVE ALARMS: MAJOR		
Sep 16 20:10:37	Spectracom	spectracom:	[system]	Frequency Error		

“GPS Antenna Problem” indicates the antenna sense circuit has detected that a short or open exists in the antenna cabling.

“Not in Sync” indicates SecureSync is not synced to any input reference.

Figure 17: Alarms Log Entries

A third indication of GPS reception issues is based on entries contained in the “Event” log. The Event Log contains a list of event changes, such as loss of time sync and Antenna Problem alarms being asserted (if the Antenna Sense circuit detected any shorts or opens in the antenna cable). To view the Event Log, navigate to this page by clicking on “Tools” on the top of the main page and then on “Logs” in the dropdown. Then click on the “Event” tab. Refer to Figure 18.

The screenshot shows a web browser window displaying the SecureSync event log. The log contains a series of entries with timestamps and system messages. Red arrows point from callout boxes to specific entries in the log:

- “GPS Antenna Problem”** indicates the antenna sense circuit has detected that a short or open exists in the antenna cabling.
- “GPS Antenna Problem Cleared”** indicates the antenna sense circuit has detected that a short or open in the cable no longer exists.
- “Too few GPS Sat”** indicates not enough satellites are currently being tracked.
- “In Holdover”** indicates SecureSync was in Sync, but has since lost all external references and is now using the internal oscillator to derive the time. Outputs are still useable.
- “No longer In Holdover”** indicates either the Holdover period has expired, or GPS reception has been restored.
- “Not in Sync”** indicates no references are available and the holdover period has since expired. Outputs may not be useable.

**Figure 18: Event Log Entries**

If the unit has intermittent GPS reception issues that are causing all GPS reception to cease, the Event Log may display “In Holdover” alarms and/or time synchronization alarms as shown in Figure 3. “In Holdover” alarms indicate the SecureSync appliance is no longer tracking any GPS satellites (and has no other external reference available), but has not yet declared the loss of Time Sync (the time is being derived from the built-in oscillator and the SecureSync is still a useable time reference). Time Sync alarms indicate the SecureSync is no longer synchronized and external devices are likely ignoring the SecureSync as a reference. “Antenna Problem” alarms in this log indicate an opens or short in the antenna cable is likely present (or the GPS antenna is not connected to SecureSync).

If both Holdover/Time Synchronization alarms and “Antenna Problem” alarms are present, the likely cause of the loss of GPS reception is due to an antenna cable issue. If Holdover/Time Sync alarms are present, but Antenna Problem

alarms are not present, the reception issue is unlikely to be due to shorts or opens in the antenna cable (unless the Antenna Sense circuit has been damaged by a surge/lightning).

### GPS Qualification Log

A third indication of GPS reception issues is based on entries contained in the “GPS Qualification” log. This log contains a running hourly count of the number of GPS satellites tracked each hour. This history data can be used to determine if a GPS reception problem exists and whether this is a continuous or intermittent reception issue. To view the GPS Qualification Log, navigate to this page by clicking on “Tools” on the top of the main page and then on “Logs” in the dropdown. Then click on the “GPS Qualification” tab.

GPS reception may be displayed as cyclic in nature. A cyclic 12 hour pattern of decreased GPS reception typically indicates that the GPS antenna has an obstructed view of the horizon. The GPS satellites are in a 12-hour orbit, so if part of the sky is blocked by large obstructions, at the same time every day (at approximately 12 hour intervals), the GPS reception may be reduced or may vanish altogether. If this occurs, the antenna should be relocated to afford it an unobstructed view of the sky.

Every hour (displayed in the log as UTC time), SecureSync counts the total number of satellites that were tracked during that hour. The GPS Qualification log shows the number of satellites that were tracked followed by the number of seconds that the particular number of satellites were tracked during the hour (3600 seconds indicates a full hour). The number to the left of the “=” sign indicates the number of satellites tracked and the number to the right of the “=” sign indicates the number of seconds (out of a total of 3600 seconds in an hour) that the unit was tracking that number of satellites. For example, “0=3600” indicates the unit was tracking 0 satellites for the entire hour, while “0=2700 1=900” indicates the unit was tracking one satellite for 900 seconds, but for the remaining portion of the hour it was tracking zero satellites.

Every hourly entry in the log also contains a quality value, represented by “Q= xxxx” (where x can be any number from 0000 through 3600). If SecureSync tracked at least four satellites for the entire hour in the standard mode or at least one satellite for the entire hour in Single Satellite Mode, the Quality value will equal 3600. For every second SecureSync tracked less than the minimum number of satellites, the value will be less than 3600. The minimum requirement is one satellite at all times after the unit has completed the GPS survey and indicates “Stationary”. A minimum of four satellites are required in order for the GPS survey to be initially completed.

If all entries in the Qualification log are displayed as “0=3600”, a constant GPS reception problem exists, so the cause of the reception issue is continuous. If the unit occasionally shows 0=3600 but at other times shows that 1 through 12 have numbers of other than “0000”, the reception is intermittent, so the cause of the reception issue is intermittent. If the Quality value normally equals 3600 but drops to lower than 3600 about every 12 hours, the issue is likely caused by the GPS antenna having an obstructed view of the sky.

### Example GPS Qualification Log entry:

6 = 151 7 = 189 8 = 480 9 = 534 10 = 433 12 = 108 Q = 3600

In this example entry, SecureSync tracked no less than 6 satellites for the entire hour. Out of the entire hour, it was tracking 6 satellites for a cumulative total of 151 seconds (not necessarily in a row). For the duration of the hour, it was tracking, 7, 8, 9, 10 and 12 satellites for a period of time. Because it was tracking at least one satellite for the entire hour, this Quality value is Q=3600.

**Note:** If SecureSync is not connected to a GPS antenna (or is never able to start tracking any satellites at all), the GPS Qualification log will remain empty.

### Timing Log

When a Rubidium oscillator is installed in the SecureSync, a fourth indication of a GPS reception issue occurring is the presence of “**Rb track off – free run**” and “**RB synchronized**” log entries in the Timing log. When there are no 1PPS input references present or considered valid (such as the GPS receiver is no longer able to track at least four satellites), it is not desired to discipline the oscillator to a potentially unstable 1PPS input reference. To prevent this from happening, when there are no valid 1PPS input references available to SecureSync, the Rubidium oscillator is automatically placed into a free run state where it is not locked/steered to any 1PPS input references.

When the oscillator is placed into a free run state, the “**Rb track off - - free run**” entry is asserted in this log. Once a valid 1PPS input reference has become available again (such as the GPS receiver is once again tracking at least four satellites, for example), the “**RB synchronized**” log entry is asserted into this log. This indicates the oscillator is now locked and being disciplined to the highest priority input reference that is available to SecureSync.

The timing log will also report if there are any opens or shorts occurring in the GPS antenna cable, as indicated by “GPS Antenna” entries being asserted into this log.

## Section 3: Troubleshooting a GPS Reception Issue

Once it has been determined that a GPS reception issue really does exist, the next step is to determine the cause of the GPS reception issue. Troubleshooting this condition is broken into two processes. Process A is to troubleshoot/resolve issues related to opens or shorts in the antenna cable. Process B is to troubleshoot/resolve issues not caused by opens or shorts in the antenna cable.

### Determining whether to use Process A (Cabling Issue) or Process B (Non-Cabling Issue)

Three main tools help determine whether to follow Process A or Process B to troubleshoot GPS reception issues. These are the built-in Antenna Sense circuit, the presence of Antenna Problem alarms in the Event Log, as well as the front panel Sync and Fault lamps (With no other valid inputs other than GPS, the Sync light won't be solid green and the fault light may be lit, if the receiver is not tracking the minimum number of satellites, as determined in Sections 1 or 2 of this document).

The SecureSync has a built-in Antenna Sense circuit that is used to detect opens or shorts in the antenna cable. The internal GPS receiver outputs 5VDC on the antenna jack to power the GPS antenna. The GPS receiver detects the current draw on this 5VDC and then indicates if the current draw is normal (OK) or abnormal (a short or open is likely present). The GPS Input Status page of the browser displays the current sense status (at this particular moment). Also, the Alarms and Events logs capture whether a short or open in the cable has been detected (as indicated by "GPS Antenna Problem" alarms being present in these logs).

The Antenna Sense circuit is connected to the front panel Sync lamp. If an open or short is detected in the antenna cable, the surge suppressor, the preamplifier, or the GPS antenna, the front panel Fault lamp will flash a blinking amber color once-per-second. If the Fault lamp is blinking amber (and a GPS splitter is not in the line), follow [Process A](#) to troubleshoot this condition.

If the "Antenna Sense" field in the GPS Input Status page of the browser indicates "OK" and the Alarms/Event log contains no "GPS Antenna Problem" alarms, the GPS antenna is connected with no opens or shorts being detected in the antenna cable. Follow [Process B](#) to troubleshoot.

**NOTE:** If a Model 8227 inline GPS preamplifier is installed between the SecureSync and the GPS antenna and a short or open exists between the preamplifier and the GPS antenna, the preamp will block the Antenna Sense from being able to detect the cable issue (the Sync LED won't blink red). Because the GPS preamplifier draws current, the GPS receiver senses this current draw as a good connection to the antenna. For this reason, it's important to ring out the antenna cable on both sides of the preamplifier, if one is installed (the preamplifier is typically installed when the cable distance between the GPS receiver and GPS antenna exceeds 300 feet with a Model 8225 antenna or 400 feet with a newer Model 8230 antenna).

**NOTE:** As of about Sept, 2011, there are three variations of the Model 8227 preamplifier. If the preamplifier case is circular, it is the earliest style. If the case is square, it is a newer style. The latest version indicates it's from "GPS Networking" with a P/N of "AR02-1587-2002". When disconnected from the GPS antenna and measured on the equipment side, the newer (square) preamplifier has an impedance of about 91 kohms and the "AR02-1587-2002" has an impedance of about 9.3 kohms.

When the preamp is measured with the antenna connected to the input side, however, the impedance is about 179 ohms. This load of 179 ohms simulates the normal load of a GPS antenna, so it can simulate an antenna connected even if a short or open exists between the GPS antenna and the preamplifier (it can provide a false indication that the cable is fine even though a cable issue exists).

## Process A: Troubleshooting Opens or Shorts in the Antenna Cable

If the “Event” log contains any unexpected “Antenna Problem” alarm entries, or if the Fault lamp is flashing amber every second, there is likely a short or open occurring in the antenna cable. Follow this process to troubleshoot this condition. A basic hand-held digital or analog voltmeter is used in the following steps.

- 1) Disconnect the GPS antenna cable from the rear panel antenna input jack of SecureSync.
- 2) As shown in Figure 19, measure the 5VDC voltage (the GPS receiver provides a nominal +5vdc to power the GPS antenna) across the rear panel antenna jack. Place the red probe of the meter on the center pin of the connector and place the black probe touching the threaded portion of the connector. There should be a nominal 4.8VDC to 4.9VDC present on this jack. If this voltage is NOT present, stop here and contact Spectracom Technical Support for additional assistance. If this 5VDC is not present, a problem internal to the SecureSync exists (the GPS receiver is not providing the +5VDC needed to power the GPS antenna). However, if the 5VDC is present, proceed to the next step.

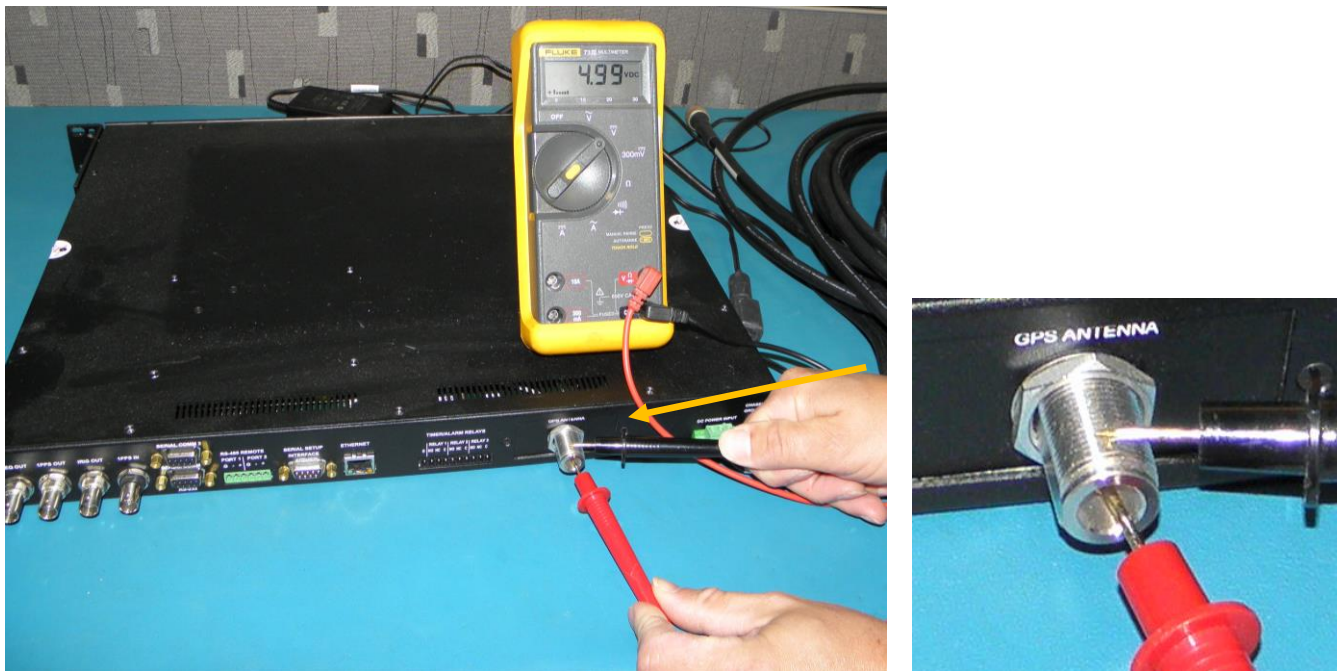

**Figure 19: Verify 5vdc is present on the GPS antenna jack**

- 3) As shown in Figure 20, with the antenna cable still disconnected from the rear panel antenna jack (and with the GPS antenna connected), verify the impedance (ohms) across the antenna cable connector (Measure the ohms from the center pin of the cable connector to the threaded portion of the connector).

**Note:** The expected impedance values depend on the Model of the antenna and are provided further below.

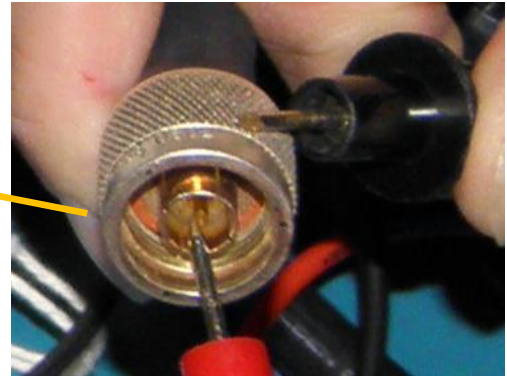
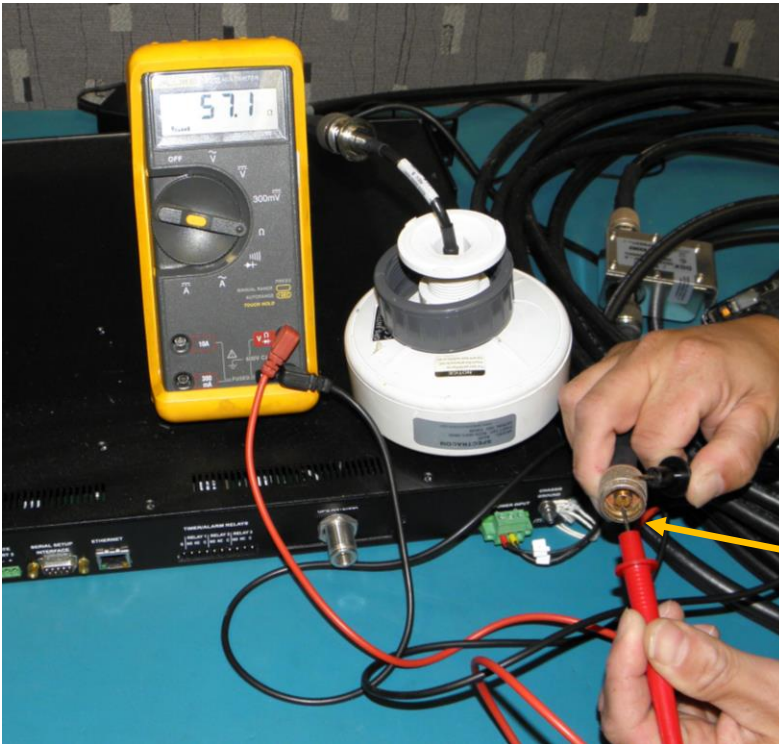

**Figure 20: Verifying impedance of the GPS antenna through the antenna cable**

**Spectracom Model 8230 GNSS antenna (replaced the earlier Model 8225 GPS antenna and started shipping ~Sept 2013)**

With the red test probe on the center pin of the cable and the black test probe on the outer thread, the Model 8230 GNSS antenna impedance is about **5.6 Mohm**.

**Spectracom Model 8225 GPS antennas**

- A. With Model 8225 GPS antennas that have a Model Number of **“CCAB32AST01”** (shipped before May of 2008, with serial numbers below 9800), this should read **177 ohms** (this is the impedance of the GPS antenna being read at the end of the cable). If a GPS preamplifier is installed in-line, this reading will be roughly **152 ohms**.
- B. With Model 8225 GPS antennas that have a Model Number of either **“SA-300”** (shipped after May of 2008, with serial numbers above 9800) or the newer **“Timing System 1000”**, this should read about **62 ohms** (this is the impedance of the GPS antenna being read at the end of the cable). If a Model 8227 GPS preamplifier is installed in-line, this reading will be roughly **179 ohms**.

**Spectracom Model ANT-35 GPS antennas**

The Model ANT-35 GPS antenna impedance starts at 1Mohms- 5 Mohms reading, and then starts to decrease. After 10 seconds or so, it stabilizes at about **690kOms- 700kOhms**.

**Spectracom Model 8225S GPS antennas (for SAASM GPS receivers)**

The Model 8225S antenna impedance starts at 1,000,000 - 5,000,000 ohms reading, and then starts to decrease. After 10 seconds or so, it stabilizes at about **4.3 Mohms**.

**RESULTS**

If the impedance measurement is correct, the antenna and cabling are ringing out OK. If the reading is low (close to, or at 0 ohms) a short exists in the antenna cable between his connector and the GPS antenna. If the impedance reading is high (reading an open), there is a break in the connection to the GPS antenna connection.

**NOTE:** If the impedance measurement of the cable is correct, but the Antenna Problem alarm is still active with the cable connected (the Fault lamp is flashing red), this indicates the internal GPS receiver’s sense circuit was likely damaged by a power surge/lightning strike. Depending on the severity of the surge, while in this state the GPS receiver may or may not be able to track satellites. The sense circuit is located in the RF input section of the GPS receiver, so the RF section may also have been affected by the surge (preventing it from being able to track satellites).

If the impedance measurement at the antenna connector is either very low or very high, there is a short or open present in the antenna cabling. Working your way back towards the GPS antenna, measure the impedance in the same manner at each connection in the antenna cable run. Make sure to verify the connections at the Model 8226 surge suppressor and Model 8227 GPS preamplifier if these devices are installed.

**To Verify a Model 8226 GPS Surge Suppressor (If installed) is likely OK**

The chance of a GPS surge suppressor being faulty is extremely small. However, a surge suppressor can be verified as OK by making two impedance checks on the input and output connectors (with the GPS antenna cable disconnected).

Measure the continuity (ohms) between the center pins of the “to receiver” and “from antenna” connectors and a short (very low ohms reading) should be present. Next, measure the continuity between the center pin of either connector to the case of the surge suppressor and this should be an open (high impedance). Refer to Figure 21.

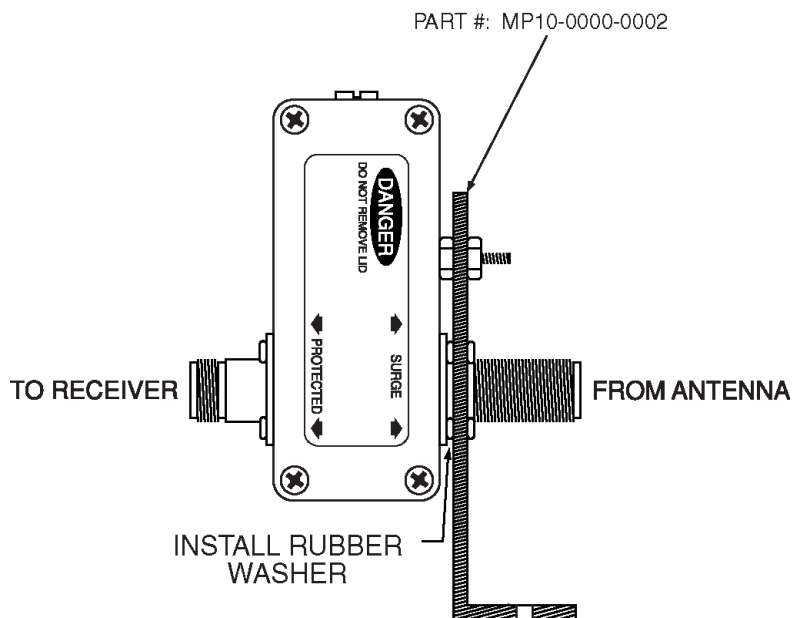

**Figure 21: Model 8226 Surge Suppressor**

As shown in Figure 22, disconnect the GPS antenna cable from the “Protected” side of the GPS surge suppressor (If installed). Test the impedance of the center pin of the “Protected” antenna cable jack of the surge suppressor to the outer-threaded portion of the connector (or anywhere on the case. If the impedance is not correct (as described in step 3), continue to check the antenna cable at the base of the GPS antenna.

**Note:** Another method to verify if a GPS Surge Suppressor is causing the loss of GPS reception is to temporarily bypass it by jumpering it out of the antenna cable. To bypass the surge suppressor, temporarily install a type N barrel connector in its place. Then, verify if the GPS receiver starts to track satellites within a few minutes. If it does start tracking, the issue is with the surge suppressor. In this scenario, it's likely that both the antenna and the surge suppressor were damaged by a severe power surge and both components will likely need to be replaced.

Contact our Sales Department at (585) 321-5800 to order replacement antennas or surge suppressors.



**Figure 22: Checking the impedance of an antenna through the “GPS suppressor”**

#### ***To Verify a Model 8230 GNSS Antenna Is Likely OK***

**Note:** The Model 8230 GNSS antennas replaced the Model 8225 GPS antennas and started shipping ~Sept 2013.

The impedance measurement of a Model 8230 GNSS antenna can be used as a quick-check to determine if the antenna is likely operational. With the antenna cable disconnected from the antenna, measure the impedance (ohms) from the center pin (red test probe) of the connector to the outer-threaded portion of the same connector (black test probe). The meter should indicate approximately **5.6 Mohms**.

#### ***To Verify a Model 8225 or ANT-35 GPS Antenna Is Likely OK***

The impedance measurement of a GPS antenna can be used as a quick-check to determine if the GPS antenna is likely operational. Disconnect the GPS antenna cable from the end of the small pigtail cable attached to the bottom of the antenna (Model 8225 only). On the open end of the pigtail, measure the impedance (ohms) from the center pin of the connector to the outer-threaded portion of the same connector. The meter should indicate approximately 177 ohms or 62 ohms (depending on the model and serial number of the antenna as described below).

- A. With Model **8225** GPS antennas that have a Model Number of “**CCAB32AST01**” (shipped before May of 2008, with serial numbers below 9800), this should read **177 ohms** (this is the impedance of the GPS antenna being read at the end of the cable). If a GPS preamplifier is installed in-line, this reading will be roughly **152 ohms**.
- B. With Model **8225** GPS antennas that have a Model Number of either “**SA-300**” (shipped after May of 2008, with serial numbers above 9800) or the newer “**Synergy Systems Timing 1000**”, this should read **62 ohms** (this is the impedance of the GPS antenna being read at the end of the cable). If a GPS preamplifier is installed in-line, this reading will be roughly **179 ohms**.
- C. The Model **ANT-35** GPS antenna impedance **starts at 1,000,000 - 5,000,000 ohms** reading, and then starts to decrease. After about 10 seconds or so, the antenna stabilizes to about **690,000 - 700,000 Ohms**.

**Model 8225 pigtail adapter cable (not applicable to the antenna Models 8230 and ANT-35)**

As shown in Figure 23, temporarily disconnect the antenna cable from the pigtail cable that is attached to the bottom of the Model 8225 GPS antenna. Measure the impedance of the GPS antenna through the pigtail cable.

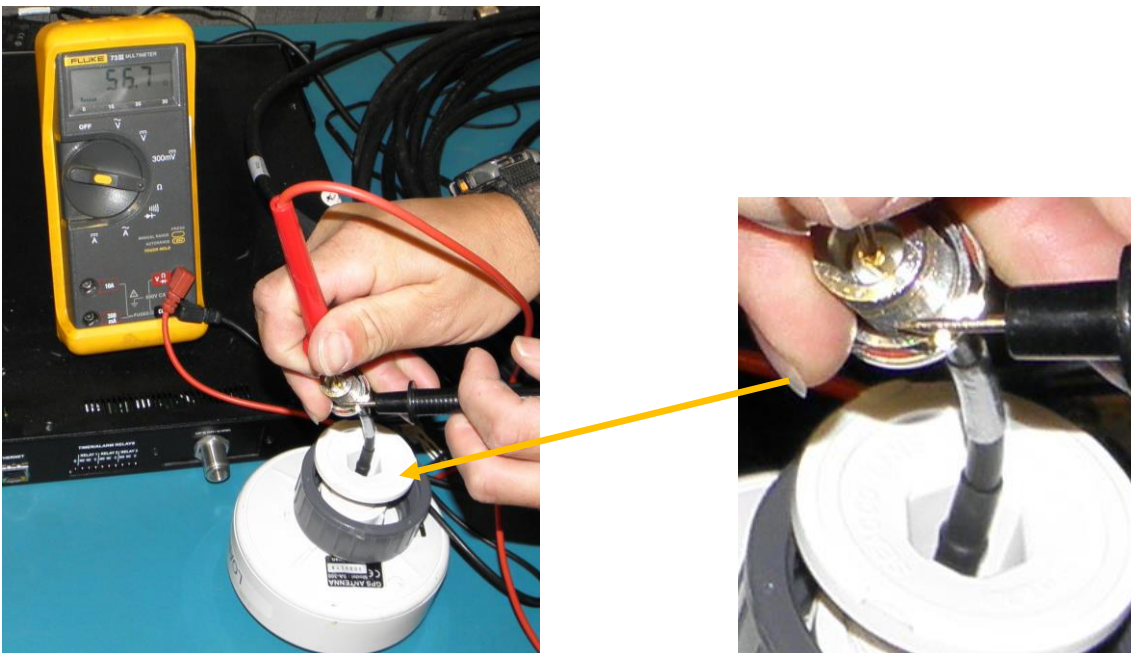

**Figure 23: Checking the impedance at the GPS antenna**

As shown in Figure 24, if an open or short is still being measured, disconnect the short pigtail cable from the bottom of the GPS antenna and measure the impedance of the GPS antenna on the small jack located on the bottom of the GPS antenna itself. Note that the plastic collar piece on the bottom of the antenna can be unscrewed and removed to gain access to this antenna jack.

This test determines if the short or open is in the pigtail cable assembly or in the GPS antenna itself. If this impedance is correct (as previously described) but an open or short was detected on the opposite end of the pigtail while it was attached to the antenna, the pigtail cable is the cause of the GPS reception issue. If the impedance is still not correct on the antenna itself, the GPS antenna is the likely cause of the GPS reception issue.

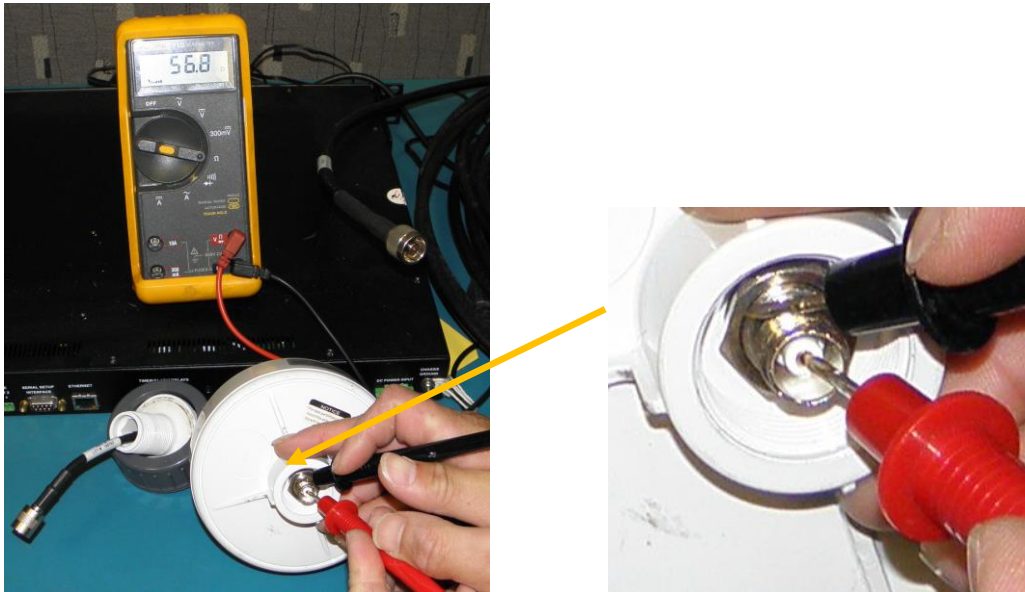

**Figure 24: Measure the impedance of the GPS antenna on the antenna jack**

Another check that can confirm whether the antenna cable has a short or open present (and to perform a quick-check of the antenna itself) is to reconnect the antenna cable onto the rear panel antenna jack of the SecureSync. Disconnect the antenna cable from the GPS antenna. Measure the DC voltage on the antenna cable connector that normally connects to the antenna. A DC voltage similar to the voltage that was measured on the SecureSync antenna jack should be present (nominal 5vdc). If this voltage is not present, there is still a short or open in the antenna cable. If the 5VDC voltage is present on the antenna cable, measure the impedance across the antenna itself. The antenna should measure about 177 ohms or 62 ohms (depending on the Model and Serial Number of the antenna as described previously).

If the 5VDC was present but the antenna indicates an open, make sure that the short pigtail cable that is connected to the antenna (the pigtail is connected to the bottom of the antenna with a small threaded connector) is nice and tight. The collar nut of the antenna can be unscrewed from the antenna for easier access to the small threaded connector. If this connector is loose, tighten it and then verify whether the unit is able to start tracking satellites or not.

#### ***To Verify a Model 8225S SAASM GPS Antenna Is Likely OK***

The impedance measurement of a Model 8225S GPS antenna can be used as a quick-check to determine if the antenna is likely operational. With the antenna cable disconnected from the antenna, measure the impedance (ohms) from the center pin (red test probe) of the connector to the outer-threaded portion of the same connector (black test probe). The meter should indicate approximately **4.3 Mohms** after a few moments.

#### ***To Verify a Model 8227 GPS Inline Preamp Is Likely OK (If Installed)***

The chance of a GPS inline preamplifier being faulty is extremely small. However, the preamplifier can be verified as OK by making an impedance check on the output connector.

**NOTE:** There are a few variations of the Model 8227 preamplifier. If the preamplifier case is circular, it is an earlier style. If the case is square, it is a newer style.

When disconnected from the GPS antenna and measured on the equipment side, the newer (square) preamplifier has an impedance of about 91 kohms. When the inline preamp is measured on connector "J1" with the Model **8225S** (SAASM antenna) connected to the antenna side, the impedance is about 4.3 Mohms. When the preamp is measured

with the Model 8225 antenna connected to the input side, however, the impedance is about 179 ohms. This load of 179 ohms simulates the normal load of a GPS antenna, so it can simulate an antenna connected even if a short or open exists between the GPS antenna and the preamplifier (it can provide a false indication that the cable is fine even though a cable issue exists).

With the GPS antenna cable disconnected from the preamplifier (just the preamp by itself), measure the continuity (ohms) between the center pin of the “GPS out” / “J1” end of the preamplifier and the threaded outer portion of the connector.

The meter should indicate approximately **152 ohms** (Round preamplifier) **91 kohms** (Square preamplifier), **9.3 kohms** (Mfg P/N “AR02-1587-2002”) or about **7Mohms** (Mfg P/N “MLA 20RPDC-N”). This indicates the preamplifier is likely OK. Refer to Figure 25, 26 and 27.



Figure 25: Older Model 8227 Inline Preamplifier

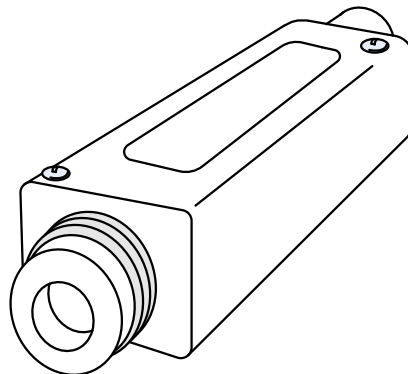

Figure 26: Newer Model 8227 Inline Preamplifier



Figure 27: more recent Model 8227 Inline Preamplifier (Mfg P/N “AR02-1587-2002”)

If the antenna cabling is verified to be OK (no shorts or opens in the antenna cable exist and 5VDC is present at the GPS antenna end of the cable) and the Model 8225 GPS antenna as well as the Models 8226 Surge Suppressor and 8227 inline preamplifier (if installed) ring out normally, yet there were unexpected “GPS Antenna Problem” alarms in the Alarms Log, this indicates the problem is an intermittent antenna cable issue.

If GPS reception is restored after ringing out the cable (and the Antenna Problem alarms no longer occur), the issue was likely due to a loose connection. If the GPS reception is not restored (and the Antenna Problem alarms continue to be asserted), the antenna cable and connections may need to be “wiggled” to determine the exact location of the fault. Both preamplifier labels indicate which end should be connected to the GPS antenna. Make sure the preamplifier is not installed backwards, as this will prevent the GPS receiver from being able to track satellites.

## Process B: Troubleshooting Cable “OK” Related Issues

Follow this section to troubleshoot reception issues not related to opens or shorts in the antenna cable (Antenna Sense circuit indicates “OK” as there are no “Antenna Problem” alarms found in the Alarm Log and the front panel Fault lamp is not flashing amber).

If reception problems are present but there are no “Antenna Problem” alarms found in the Event Log, the cabling to the GPS antenna is likely fine. The problem could be some sort of local interference, the antenna’s view to the sky might be obstructed, the type/length of the antenna coax cable in use may be unsuitable, or the problem might be in the SecureSync or specific to the antenna itself.

Check the antenna location. The antenna should have as unobstructed a view of the horizon as possible. Relocate the antenna as necessary to increase the view of the horizon.

If the antenna cable was purchased locally instead of from Spectracom, make sure the cable loss of the cable at the GPS frequency (1.575 GHz) is comparable with the loss of LMR-400 cable (about 5 dB/100 feet of cable length). If the cable has a much higher cable loss, a preamplifier may be required. The cable run may be too long even with a preamplifier installed. Contact Spectracom Technical Support if necessary for assistance with calculating the cable loss to determine if the cable can be used and if a preamplifier is required to boost the signal to a useable level.

If using a Model 8228 indoor window-mount antenna instead of the Model 8225 outdoor GPS antenna, refer to Section 3 of this document. The window-mount antenna has specific requirements for proper operation.

With the exception of a few known GPS harmonic frequencies, GPS is rarely affected by other RF radiated noise sources. The few known harmonic frequencies that are transmitted from TV and FM radio can interfere with GPS reception if the antenna is installed in close proximity of the transmitter. The stations that can interfere with GPS are listed below.

CHANNEL	HARMONIC	Actual Frequency
66	2 <sup>nd</sup>	783.25 MHz
23	3 <sup>rd</sup>	525.25 MHz
10	8 <sup>th</sup>	193.25 MHz
7	9 <sup>th</sup>	175.25 MHz
6	18 <sup>th</sup> & 19 <sup>th</sup>	83.25 MHz
5	20 <sup>th</sup>	77.25 MHz

### Television Stations with GPS Jamming Potential

FREQUENCY	HARMONIC
104.8 - 105.2	15 <sup>th</sup>
98.3 - 98.7	16 <sup>th</sup>
92.5 - 92.9	17 <sup>th</sup>
87.3 - 87.7	18 <sup>th</sup>

### FM Radio Frequencies with GPS Jamming Potential

The operation of dish–style transmitting antennas (such as those used for weather radar), Hughes Network dish antennas for Internet service, and VPN/IP phones in proximity to the receiver may also interfere with GPS reception.

The GPS antenna should be located away from the line-of-sight transmission of these other devices to prevent local interference.

To confirm that the equipment is operating properly, the best test is to take the SecureSync, the GPS antenna, and a length of coax cable to a different location. Connect them, power up the SecureSync, and check to see if the SecureSync is able to track satellites. Place the antenna in an area with a clear view of the sky, wait about 20 minutes, and verify that the Sync lamp turns green. If the Sync lamp does turn green, the equipment is operating normally and the issue is likely site-related.

Due to limitations at the site, it may not be possible to track four or more satellites at all times. If the SecureSync has limited GPS reception, refer to Section 3 to operate the unit in the single-satellite mode. This mode reduces to one the minimum number of satellites required to achieve and maintain time sync.

The SecureSync appliance must track four satellites for several minutes during initial installation. Upon completion of the GPS survey (or after manually entering the latitude and longitude if the receiver can never track four satellites), this requirement drops to just one satellite from that point forward. Only if the SecureSync can never track four satellites (or the location can't be entered manually) should these units be placed in the single satellite mode of operation.

***Specific to only SecureSyncs with a SAASM GPS receiver installed (note this GPS receiver is only available to qualified US Military/DOD/NATO organizations)***

If the SecureSync has a SAASM GPS receiver installed (as shown in the Figure below) it will have a “Fill” connector and a “Zeroize” switch on the front panel of the NetClock).

**Note:** If this additional switch and connector aren’t installed on the Front Panel as shown below, disregard this section.



**Figure 28: Connector and switch for SAASM receiver**

If the SecureSync is not tracking any satellites or if it’s tracking a very low number of satellites (<4), perform the following steps:

- 1) Zeroize the GPS receiver.
- 2) See if the receiver starts tracking a normal number of satellites (>4)
- 3) After at least an hour of good reception, reload the keys.
- 4) Verify the receiver continues to track at least four GPS satellites.

**Note:** The SAASM receiver outputs only **3.3vdc** (instead of 5vdc, as outputted by the commercially available receivers) to power its GPS antenna.

Please contact Spectracom Tech Support if you have any questions on the above information, or if the SAASM receiver continues to have a GPS reception issue after re-loading the keys.

If the GPS Reception Problem Persists After Performing Process A or Process B

If, after using this document to troubleshoot a satellite reception issue, a reception problem still exists, email or fax the following requested data to Spectracom ([techsupport@spectracomcorp.com](mailto:techsupport@spectracomcorp.com) or fax US +1.585.321.5219):

1. Send us a bundle file of the unit's logs. Depending on the current version of software installed, there are two main ways to easily obtain the logs to send to us.

**A) With software versions 5.1.2 and above installed**

Instead of copy/pasting all of the log entries into a Word document, starting in Archive software update version 5.1.2, the logs can be easily saved to single bundled file and exported into a networked PC. Earlier versions of software allowed the bundle to be created, but then the file still needed to be transferred out using an FTP/SCP connection. Now, a button in the web browser alleviates the need to create an FTP session to transfer this file out to a PC.

The log bundling and export to a PC is controlled in the **"Management" -> "Log Configuration"** page of the SecureSync's web browser. On the left-side of the browser, click on the **"Save and download all logs"** button. You can then select where to save the log bundle to. The default file name is "securesync.log".

**B) With software versions 5.0.2 and below installed**

Instead of copy/pasting all of the logs to a Word document, you can also bundle the logs into a single log file. Then export this bundle file from the SecureSync using an FTP or SCP session. Then, simply attach this extracted file to a reply email. Below is additional information on how to bundle and extract all of the unit's logs:

The log bundling is controlled in the **"Tools" -> "Upgrade/Backup"** page of the SecureSync's web browser. Click on the "Configuration" tab. Then, to bundle the logs, change "Save Log Files" to "Enabled" and then hit Submit. This generates a single file bundle of the logs. This file ("securesync.log") is placed in the **"home/spectracom/xfer/log/"** directory. Once it has been created, you can FTP/SCP it off the box (just make sure "FTP Service" is enabled in the Network/General page of the browser, "Services" tab).

If you need a free FTP client, we often use CoreFTP (<http://www.coreftp.com/>).

2. Copy/paste:

**A) From the new web browser:** The **"GNSS 0"** status pop-up window from the **Interfaces -> GNSS 0** page, **"Main"** tab.

**B) From the Classic Interface:** the **GPS Input Status** table logs from the **Status -> Inputs** page (then click on the **"On-Board Reference GPS"** box).

3. The DC voltage measured on the GPS antenna connector.
4. The impedance measurements of the GPS antenna cable.
5. A description of where the antenna is mounted and what is near the antenna.
6. The type (Such as "Belden RF-400") and total approximate length of the GPS antenna cable (GPS receiver to the GPS antenna).
7. Whether a GPS preamplifier and/or a GPS splitter are being used.

Spectracom will analyze the provided data and recommend a course of action.

## Section 4: Using a Model 8228 Window-Mount Antenna with SecureSync

Spectracom offers a window-mount GPS antenna (Model 8228) that can be used for installations in which an outdoor GPS antenna is not desirable or feasible. There are specific factors that must be addressed when using this, or any other Model GPS/Glonass antenna indoors.

Any tinting or metallic screening present on or in the glass is likely to attenuate the GPS/Glonass signal to unusable levels. Also, building overhangs and other nearby buildings may block the GPS satellites from view. The antenna must be installed in a window (because of the orbits of the GPS satellites, it makes very little difference on which side of the building the antenna is installed) that has an unobstructed view of the sky and which bears no tinting or screening on the glass. If there is tinting or screening on the glass, the SecureSync will probably not be able to track satellites.

Even if the antenna is installed in a window with no tinting or screening on the glass and a good view out the window, the building itself blocks a majority of the satellite orbital view. Window-mounted antennas will normally track less than four satellites because of this.

SecureSyncs have a selection option for Single Satellite Mode, but this is for last-case scenarios and should only be used if the latitude and longitude cannot be entered by GPS and can't be manually entered by a user. At least once, SecureSync must track a minimum of four satellites for at least 33 minutes in order to calculate the unit's position and achieve a 3-D fix. Once the GPS receiver goes into "Stationary" mode, the SecureSync requires only one satellite from that point forward to maintain GPS as a valid reference for time sync. If four satellites for the minimum required duration cannot be reached, the GPS location (latitude and longitude) can be manually entered, thereby placing the GPS receiver in Position Hold mode.

To manually enter an "accurate" GPS position (as determined by a smart cell phone with a GPS App or a hand-held Garmin type GPS receiver, for examples) open the SecureSync's web browser and:

### A) Newer web browser (Software versions 5.1.2 and above)

1. Click on "**Interfaces**" at the top of the web browser and select "**GNSS 0**".
2. Click on "**Edit**" (at the bottom of the window).
3. Enter the determined latitude, longitude and antenna height into the "Manual Position Setup" table.
4. Press Submit.

### B) Classic interface web browser (Software versions 5.0.2 and below)

1. Click on "**Setup**" at the top of the web browser and select "**Inputs**".
2. Select "**GPS**" (in the blue box).
3. Enter the determined latitude, longitude and antenna height into the "Manual Position Setup" table.
4. Press Submit.

If the minimum number of satellites can't be maintained, the SecureSync will enter holdover mode and may even lose time sync. The amount of time during which the unit can stay in the holdover mode is determined by the setting in the Holdover screen. In newer versions of the software, this value can be lengthened from the default setting (an option known as variable holdover). If the unit is losing time sync because it can't maintain at least one satellite, lengthening the holdover value may prevent the loss of time sync. Refer to Section 1 of this document for information on using the GPS Qualification and Event Logs to determine how often the SecureSync is going into holdover (or possibly even losing Time Sync).

### Holdover period

To change the available length of Holdover (time between the loss of all references until Time Sync is lost):

Desired Holdover length	Desired Holdover length (in seconds) to be entered
2 hours	7200 (factory default value)
24 hours	86400
7 days	604,800
30 days	2,419,200
1 year	29,030,400

**Table 1: Holdover conversion table**

#### A) With Software versions 5.1.2 and above installed

1. Navigate to the **Management** -> **Disciplining** page of the browser.
2. Click on the “gearbox” ICON to the right of “**Status**” (in the upper-left corner of the page)
3. In the “Oscillator Settings” pop-up menu, configure the “**Holdover Timeout**” field (Entered and displayed in seconds) for the maximum allotted time the NetClock can be “synchronized with no valid reference inputs being. Refer to Table 1 above for a list of commonly desired Holdover periods.

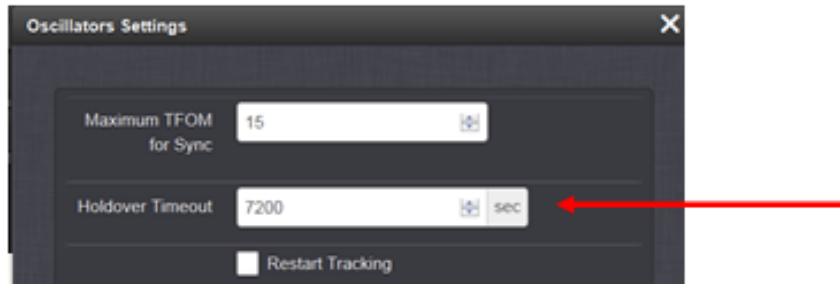

**Figure 29: GPS Input configuration screen**

#### B) With Software versions 5.0.2 and below installed

1. Click on “**Setup**” at the top of the web browser and select “**Disciplining**”.
2. Configure the “**Holdover Timeout**” field (Entered and displayed in seconds) for the maximum allotted time the NetClock can be “synchronized with no valid reference inputs being present. Refer to Table 1 above for a list of commonly desired Holdover periods.

### Single Satellite Mode

To place the SecureSync into Single Satellite Mode (not recommended unless it's impossible to initially track at least four satellites and the latitude and longitude can't be manually entered):

**A) With Software versions 5.1.2 and above**

1. Click on **Interfaces** → **GNSS 0** at the top of the web browser and select **“Edit”**.
2. Change the **“Receiver Mode”** drop-down to **“Single Satellite”** and then hit Submit.

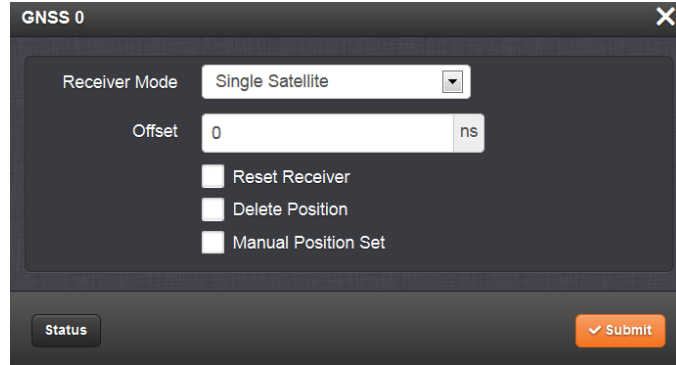

**Figure 30: GPS Input configuration screen**

**B) With Software versions 5.0.2 and below**

1. Click on **“Setup”** at the top of the web browser and select **“Inputs”**.
2. Then Select **“GPS”** (in the blue box).
3. Change the **“Receiver Mode”** drop-down to **“1 satellite”** and then hit Submit.

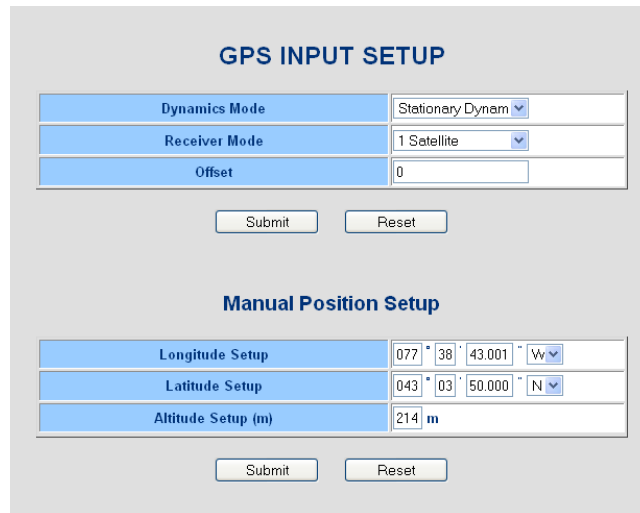

**Figure 31: GPS Input configuration screen**

SecureSync will require only one satellite to achieve time sync. If the unit maintains at least one satellite (or has other available and valid input references, it won't enter the Holdover mode. Holdover is the time frame between the loss of the minimum number of satellites (and other input references) and the moment the SecureSync declares loss of time sync (when other devices may start to ignore the SecureSync). During Holdover mode, the time is derived from the oscillator inside of the unit.

If it is physically impossible to install the antenna in a window that doesn't have any tinting or screening on or in the glass, or if physical obstructions prevent the antenna from being able to see enough of the sky to track satellites, contact the Spectracom Sales department at US +1.585.321.5800 to discuss replacing the window-mount antenna and cabling with an outdoor antenna, cabling, and surge suppressor.

## Spectracom Technical Support

Please contact Spectracom Technical support for any additional troubleshooting assistance. Tech support is available via phone or email at the following locations:

**USA** | 1565 Jefferson Rd | Rochester, NY 14623 | +1.585.321.5800 | [sales@spectracomcorp.com](mailto:sales@spectracomcorp.com)

**FRANCE** | 3 Avenue du Canada | 91974 Les Ulis, Cedex | +33 (0)1 64 53 39 80 | [sales@spectracom.fr](mailto:sales@spectracom.fr)