



The information and instructions contained in this document have been produced in accordance with Alternative Procedure to DOA EASA AP058.

KANNAD 406 ELTs GUIDELINES FOR PERIODIC INSPECTION

1. REASON

Testing the various elements of KANNAD ELTs is mandatory at each battery replacement (approximately 6 years interval). The only periodic check required by Orolia S.A.S. is the monthly self-test as described in the Installation/Operation manual. However, some Civil Aviation Authorities may require the ELT be tested periodically.

Periodicity and List of applicable tests are defined by local regulations.

The following guidelines are provided by Orolia S.A.S. to describe usual operations required by major Aviation Authorities.

It is the responsibility of the Customer to determine which tests are applicable to its ELT.

2. EFFECTIVITY

This Service Letter is applicable to the following types of ELTs manufactured by OROLIA S.A.S., listed below:

Type of ELT	P/N
KANNAD 406 ATP	S1819502-02
KANNAD 406 AP	S1820502-01/02
KANNAD 406 AP-H	S1820502-04
KANNAD 406 AF	S1821502-01/02
KANNAD 406 AF (6D)	S1821502-06
KANNAD 406 AF-H	S1822502-01/02
KANNAD 406 AS-BNC	S1823502-01/02
KANNAD 406 AS-TNC	S1823502-03
KANNAD 406 SURVIVAL	S1823502-05

Date: MAR 16/2020
Rev. 06

SL S18XX502-25-12

Page 1 of 14

3. DESCRIPTION

A. USA (FAA)

The following regulation applies to the USA

USA: FAR 91.207 paragraph (d):

«Each emergency locator transmitter [...] must be inspected within 12 calendar months after the last inspection for --

- (1) Proper installation;*
- (2) Battery corrosion;*
- (3) Operation of the controls and crash sensor; and*
- (4) The presence of a sufficient signal radiated from its antenna. »*

B. CANADA (TCCA)

The following regulation applies to CANADA

CAR Part VI - Standard 625 Appendix C – 12 (b)(i):

ELTs [...] shall be maintained at intervals not exceeding:

- (A) 12 months, in accordance with the applicable operational test requirement in Appendix G of Standard 571; and*
- (B) 24 months, in accordance with the applicable performance test requirement in Appendix G of Standard 571.*

CAR Part V - Standard 571 Appendix G:

Maintenance of Emergency Locator Transmitters (ELTs)

(3) Operational Test [...]

(3)(a) [...] ELT Self-test [...]

(4) Performance Test [...]

(4)(b)(i) Inspection of the ELT [...]

(4)(b)(ii) measured peak power of the 406 MHz and 121.5 MHz transmissions [...]

(4)(b)(iii) measured frequencies of the 406 MHz and 121.5 MHz transmissions [...]

(4)(b)(iv) verification of 406 MHz digital message [...]

(4)(b)(v) 121.5 MHz audio modulation [...]

(4)(b)(vi) measured current draw [...]

(4)(b)(vii) test of the automatic activation system [...]

C. EUROPE (EASA)

The following regulation applies to EUROPE

SIB 2019-09R1:

EASA recommends that [...] operators [...] accomplish on an annual basis [...] a visual inspection of the ELT(AF) and ELT(AP) combined with a test and an inspection

[...]

- ELT installation [...]*
- Absence of battery defect [...]*
- [...] absence of wear [...]*
- G-switch operation;*
- Transmitted power and frequencies.*

D. Other Countries

Other countries: refer to local regulations

E. Special Airworthiness Information Bulletin

NOTE: SAIB HQ-12-32 is only applicable to Automatic Fixed (AF) and Automatic Portable (AP) ELTs.

Special Airworthiness Information Bulletin (SAIB) HQ-12-32 has informed emergency locator transmitter manufacturers as well as installers and aircraft maintenance personnel of a concern with the ability of hook and loop style fasteners to retain their designed capability to restrain emergency locator transmitters during accident impact. In several recent aircraft accidents, ELTs mounted with hook and loop style fasteners, commonly referred to as Velcro®, have detached from their aircraft mounting. The separation of the ELT from its mount caused the antenna connection to sever, rendering the ELT ineffective.

For ELT manufacturers who previously utilized hook and loop style fasteners for ELT retention, FAA recommends they include the following information in their ICA:

1. Instructions for properly securing the ELT during installation and reinstallation as well as a method to determine the appropriate tension of the hook and loop style fasteners.

2. Instructions for inspecting hook and loop style fasteners for wear, contamination, environmental degradation, or other effects to ensure they will continue to meet the requirements in the applicable TSO. Incorporating this inspection with the inspection required by 14 CFR § 91.207 is appropriate.

3. Replacement interval for the hook and loop style fasteners.

CAUTION: AN INCORRECT TIGHTENING OF THE HOOK AND LOOP FASTENER COULD LEAD TO AN UNSAFE SITUATION PREVENTING THE TRANSMISSION OF THE DISTRESS MESSAGE BY THE ELT.

For further information refer to Orolia S.A.S. Service Bulletin "SB S1800000-25-00_Rev01 All KANNAD ELTs. Check of straps for mounting mechanisms". This Service Bulletin is available on Support page of Orolia Web site.

4. TOOLS

Depending on the tests to be performed, the following tools may be required:

- 50 Ohm BNC Load, 1 Watt.
NOTE: 50 Ohm TNC Load, 1 Watt (or adapter TNC-BNC) is required for KANNAD 406 AS-TNC, P/N S1823502-03 and KANNAD 406 AS SURVIVAL P/N S1823502-05.
- Torque-limiting driver with T10 bit for all ELTs except S1819502-02. ALLEN 4 Bit for ELT P/N S1819502-02
- COSPAS-SARSAT Decoder (any decoder capable to decode a COSPAS-SARSAT digital message compatible with 406.025MHz frequency, also called "Beacon Tester". Example BT200-1100 or IFR4000 opt 1).
- 121.5 MHz VHF receiver (Aircraft VHF receiver may be used).
- Frequency meter (or any device able to measure the frequency of the 121.5MHz. Example BT200-1100 or IFR4000 opt 1)
- Wattmeter (or any device able to measure the power of the 121.5MHz. Example BT200-1100 or IFR4000 opt 1)
- Digital voltmeter with min/max recording.
- Tank capable to contain enough water to perform a water-tightness test if the ELT is opened.

The following tools are required only if current draw measurement is performed:

- 9 V DC power supply, current 3 A.
- Plug: 2xpins female AMP 170366-1, with connector AMP1722331;
2x pins male AMP 170364-1, with connector AMP 1721651.
- Ammeter with μ A range.

5. PROCEDURE ACCORDING TO FAR91.207 & EASA SIB No.: 2019-09R1

CAUTION: When actioning the ON/OFF/ARM switch, PULL LEVER TO UNLOCK and SET TO POSITION.

NOTE: Except when explicitly mentioned, always let the switch on OFF position during inspection.

A. Proper Installation

- (a) Remove the ELT from its mounting bracket (refer to relevant operation and installation manual).
- (b) Inspect the mounting bracket and the ELT: ensure the mounting bracket and the ELT are free of cracks or other obvious damage.
- (c) Check that the strap does not show traces of wear and tear due to ageing.
- (d) Inspect the connectors, cables and antennas (external and auxiliary in case of AP ELT): visually inspect all pins of connector.
- (e) Do a visual check of the locking latches of the ON/OFF/ARM switch: make sure that the 4 locking latches are not damaged as described in Figure 1.

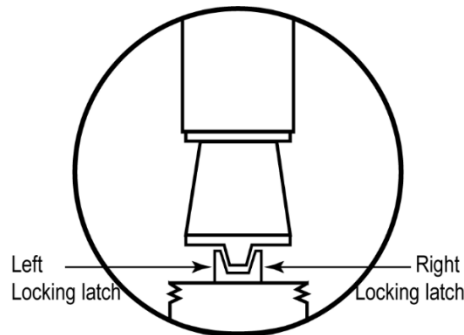

Figure 1: Locking latches of the ON/OFF/ARM Switch

- (f) If the ELT is fitted with a floating collar, ensure the absence of wear and puncture of the polyethylene foam that may affect the floating capability.

B. Battery corrosion / Battery Voltage Measurement

IMPORTANT: The ELT is hermetically closed. Unless it is mandatory, Orolia S.A.S. recommends not opening the ELT.

Due to the technology used for KANNAD ELTs and battery packs, any corrosion between two battery replacements is unlikely to happen. Orolia S.A.S. recommends an alternative way of checking the batteries by measuring the voltage of the battery without opening the ELT.

If it is mandatory to open the ELT for a visual inspection of the battery, refer to [7.E Disassembly and 7.G Assembly](#).

(1) **Battery voltage measurement**

- (a) Connect a 50 Ohm load to the ANT receptacle.
- (b) Connect the digital voltmeter between the following contacts of DIN12 connector:
 - a. L (ground) and G (common) for ELTs variants -01 (S182X502-01)
 - b. G (RCP COMMON) and A (RCP RESET) for other ELTs variants (-02, -03, -04, -05, -06)



Figure 2: DIN-12 Connector Pin-out

- (c) Perform a self-test on the ELT (switch to ARM).
- (d) Measure the battery voltage with digital voltmeter and check the voltage during the 406 MHz transmission.
- (e) Record the minimum voltage: the measured voltage must be more than 7.5 VDC
- (f) Return to the OFF position

NOTE: the minimum voltage must be recorded during the 406 MHz transmission (duration 440 ms). If the MIN HOLD feature of the voltmeter is activated before the switch to ARM, the voltmeter will record ~0V as minimum voltage. The MIN HOLD must be activated right after the ELT has been switched to ARM.

C. Operation of the Controls and Crash Sensor

(1) **Operation of controls and crash sensor for automatic ELTs**

NOTE: Not applicable to ELT of S type (KANNAD 406 AS BNC, P/N S1823502-01/02; KANNAD 406 AS TNC, P/N S1823502-03; KANNAD 406 SURVIVAL, P/N S1823502-05) which are not fitted with automatic shocks sensor (G-Switch).

IMPORTANT: Do not operate for more than 50 seconds.

- (a) Connect a 50 Ohm load to the «ANT» receptacle.
- (b) Switch to ARM and wait for the end of the self-test.
- (c) Check operation of the crash sensor:
 - For KANNAD 406 AP and AF and KANNAD 406 ATP, cause abrupt move of the ELT towards the front (refer to flight direction arrows on upper label of ELT).
 - For KANNAD 406 AP-H and AF-H, cause abrupt move of the ELT towards the front with the ELT having a 45-degree upward tilt.
 - For KANNAD 406 AF (6D), cause abrupt move of the ELT for each of the six directions (towards the front, downwards, upwards, towards the rear, the left and the right).
- (d) Make sure that the ELT operates (aural and visual indicator activated).
- (e) Switch the ELT to OFF.
- (f) Disconnect the 50 Ohm Load.

(2) **Operation of controls for automatic ELTs with RCP**

This test is not required by EUROPE (EASA);

These tests have to be performed with the Remote Control Panel (RCP).

- (a) Re-install the ELT onto its mounting bracket
- (b) Connect the outside antenna and RCP to the ELT.
- (c) Perform RCP operational tests: Refer to [Figure 3: Operation of Controls with RCP](#).

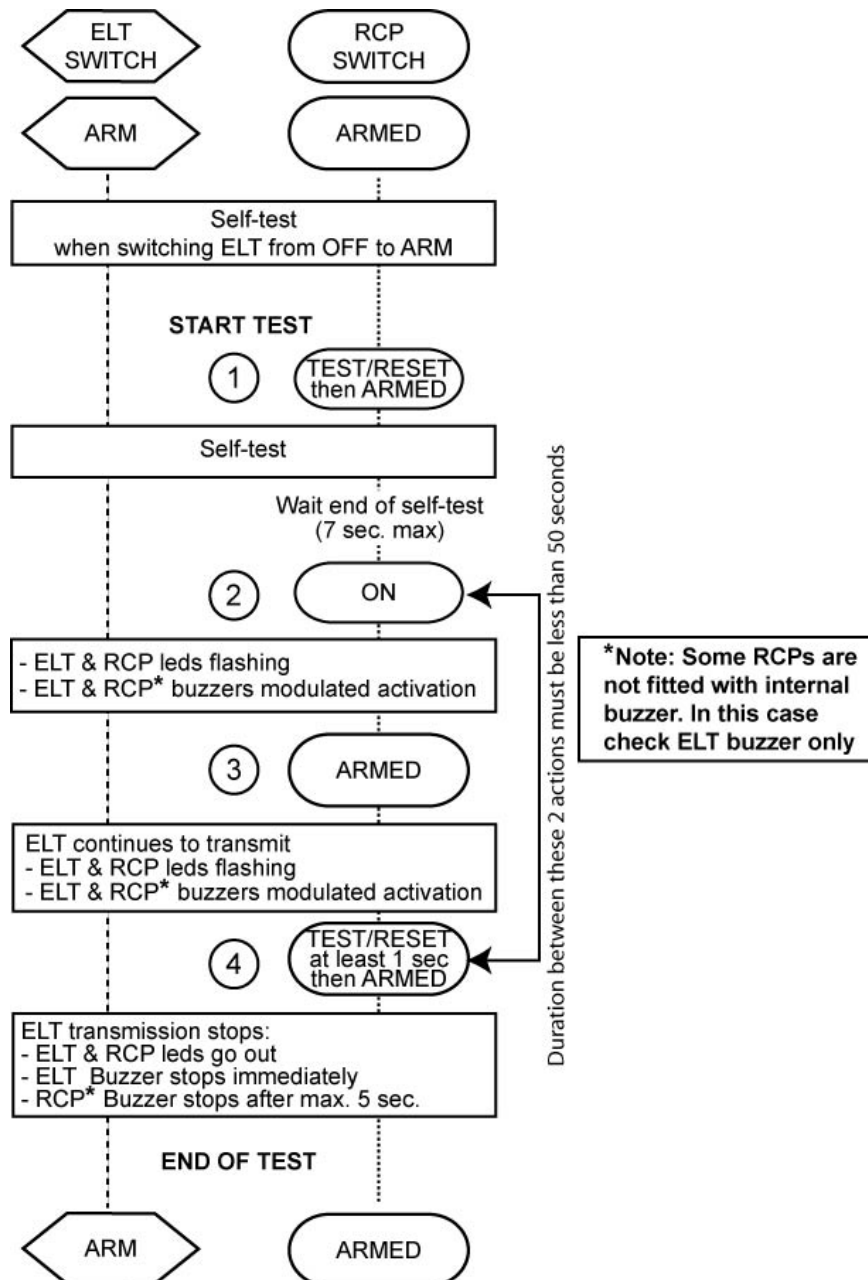

Figure 3: Operation of Controls with RCP

Date: MAR 16/2020
Rev. 06

SL S18XX502-25-12

(3) **Operation of controls for Survival ELTs**

This test is not required by EUROPE (EASA);

NOTE: Only for KANNAD 406 AS BNC, P/N S1823502-01/02; KANNAD 406 AS TNC, P/N S1823502-03; KANNAD 406 SURVIVAL, P/N S1823502-05.

(a) Ensure that the antenna is connected and unfolded

(b) Set the ELT switch from OFF to ARM:

After approximately 5 seconds, the red LED on the front panel shows the result of the self-test:

- A long flash at the end of the self-test indicates that the ELT is operating correctly;
- Short flashes indicate an operating failure (refer to relevant operation manual and installation manual).

(c) Return to OFF position

D. Presence of a Sufficient Signal Radiated from its Antenna

- If not previously installed for operation of controls, re-install the ELT onto its mounting bracket
NOTE: except for KANNAD 406 AS BNC P/N S1823502-01/02; KANNAD 406 AS TNC P/N S1823502-03 and KANNAD 406 SURVIVAL, P/N S1823502-05.
- Connect the outside antenna to the antenna connector of the ELT.
NOTE: except for KANNAD 406 AS BNC P/N S1823502-01/02; KANNAD 406 AS TNC P/N S1823502-03 and KANNAD 406 SURVIVAL P/N S1823502-05 which have to be connected to their auxiliary antenna.

(1) **406 MHz transmission test (optional on FAR91.207)**

Although this test is optional according to FAR 91.207, Orolia S.A.S. recommends performing this test if possible.

This test must be carried out with a COSPAS-SARSAT decoder.

When performed a few meters away from the ELT antenna, this test also validates the antenna radiation.

(a) Perform a self-test.

(b) Check the 15HEXID displayed by the COSPAS SARSAT tester. It must be identical to the programmed 15HEXID.

(2) **121.5 MHz transmission test**

CAUTION: The short 121.5 MHz transmission may be received by a nearby control tower. According to your local regulations, it may be recommended to conduct this test during the first five minutes of any UTC hour.

This test must be carried out with a VHF receiver.

If the antenna was already validated with the 406 MHz transmission test (see above), the on-board aircraft VHF receiver may be used.

If a 406 MHz transmission test was not performed (no Cospas-Sarsat decoder) another VHF receiver must be used, placed at a distance of at least 10 meters (30 ft.), in order to validate the antenna.

- (a) Check that the antenna is correctly connected.
- (b) Tune aircraft radio to 121.5 MHz and ensure you can hear it.
- (c) Start transmission:
 - Either on ELT: Set the switch to ON,
 - Or on the Remote Control Panel for ELTs connected to an RCP: Set the switch to ON (the ELT shall be in ARM position).
- (d) After the self-test sequence, listen to the 121.5 MHz swept tones during not more than the first five seconds then stop transmission:
 - Either on ELT, switch from ON to OFF.
 - Or, when a remote control panel is connected press RESET & TEST on the Remote Control Panel (ensure that the ELT switch is in the ARM position).

NOTE: At the end of the self-test, the test result is displayed with the red visual indicator and the buzzer will sound:

- One long flash indicates that the system is operational and that no error conditions were found.
- A series of short flashes indicates the test has failed.

The number of flashes gives an indication of the faulty parameter detected during the self-test.

- 3+1 LOW BATTERY VOLTAGE.
- 3+2 LOW RF POWER.
- 3+3 FAULTY VCO LOCKING (FAULTY FREQUENCY).
- 3+4 NO IDENTIFICATION PROGRAMMED.
- 3+5 LOW G-SWITCH VOLTAGE, **for KANNAD 406 ATP only**

- (e) Continue to listen to 121.5 MHz for a few seconds to ensure that the ELT does not continue to transmit after the test is terminated.

IMPORTANT: Do not allow test duration to exceed 5 seconds after the end of the self-test sequence. If the ELT operates for approximately 50 seconds, a 406 MHz signal is transmitted and is considered valid by the satellite system.

6. Operational Testing (Every 12 Months) - CAR Part V - Standard 571 Appendix G (3):

CAUTION: When actioning the ON/OFF/ARM switch, PULL LEVER TO UNLOCK and SET TO POSITION.

A. Self-test & 121.5 MHz transmission test

Refer to: [5.D Presence of a Sufficient Signal Radiated from its Antenna](#)

7. Performance Testing (Every 24 Months) - CAR Part V - Standard 571 Appendix G (4):

CAUTION: When actioning the ON/OFF/ARM switch, PULL LEVER TO UNLOCK and SET TO POSITION.

A. Inspection of the ELT

Refer to: [5.A Proper Installation](#)

B. Measured peak power, frequencies, digital message on the 406 MHz and 121.5 MHz transmissions

Connect the BNC connector of the ELT front panel to the BT200-1100 or any equivalent COSPAS-SARSAT tester.

(a) Switch the ELT to ARM.

(b) Measure these frequencies and power values:

- a. Transmission at 121.5 MHz
 - Frequency: 121.5 MHz \pm 0.006 MHz
 - Power: 20 to 26 dBm
- b. Transmission at 406.025 MHz (one transmission at intervals of 50 seconds)
 - Frequency: 406.025 MHz \pm 0.002 MHz.
 - Power: 37dBm \pm 2 dB
- c. Check the 15HEXID displayed by the COSPAS SARSAT tester. It must be identical to the programmed 15HEXID.

(c) Switch the ELT to OFF.

C. Audio modulation

(a) Connect the ELT to the beacon tester.

(b) Switch the ELT to ON.

Do not operate for more than 50 seconds.

(c) Make sure that the modulation factor is between 85% and 100%.

NOTE: The modulation starts AFTER the end of the self-test.

(d) Switch the ELT to OFF.

(e) Disconnect the COSPAS-SARSAT tester

D. Automatic activation system

Refer to [5.C Operation of the Controls and Crash Sensor](#)

E. Disassembly

IMPORTANT: Do not keep the ELT opened more than 2 hours.

- (a) Remove the screws (1) that hold the lower cover (2).
NOTE: Eight screws for all ELTs except P/N S1819502-02, nine screws for P/N S1819502-02.
- (b) Remove the lower cover (2).
- (c) Take the battery (3) out of its housing (4) without disconnecting it.
- (d) Check there are no traces of corrosions on the battery pack (3).

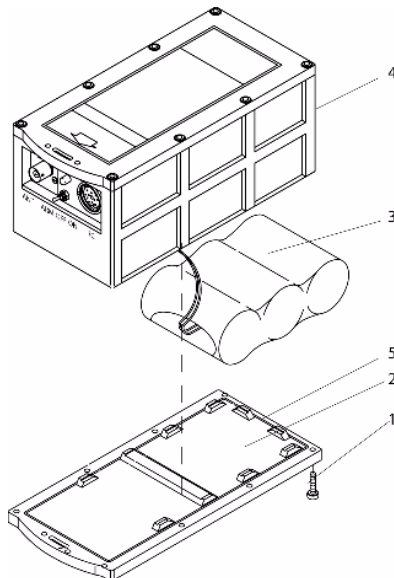

Figure 4: Opening / Closing the ELT
(Except for P/N S1819502-02)



Figure 5: Opening / Closing the ELT
(For P/N S1819502-02 Only)

F. Measured current draw.

- (a) Connect a 50 ohms load to the ANT connector.
- (b) Set up the test model for current measurement (see [Figure 5](#)).

NOTE: The ELT battery pack can also be used instead of a 9 VDC power supply.

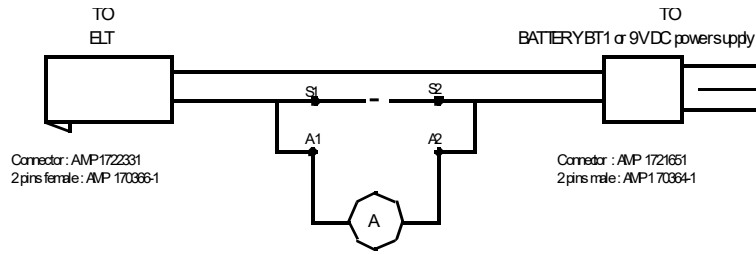

Figure 6: Test model for current measurement

- (c) Connect an ammeter with a range more than 2 A to pins A1 and A2 of the test model.
- (d) If available select the "MAX HOLD" function.
- (e) Set the ELT to ARM:
 - The ELT performs a self-test
- (f) Measure the maximum current during the self-test procedure (duration approx. 500 ms during 406.025 MHz transmission):
 - Current maximum value must be less than 2.2 A
- (g) Connect S1 to S2 (put a jumper).
- (h) Replace the ammeter by a micro-ammeter (range 100 μ A).
- (i) Disconnect S1 from S2 (remove the jumper).
- (j) Measure the current in standby mode.
 - Current must be less than 50 μ A.
- (k) Set the ELT to OFF.

G. Assembly

(1) Reinstallation of the battery pack

Refer to [Figure 3](#) and [Figure 6](#) for all ELTs except P/N S1819502-02.

Refer to [Figure 4](#) and [Figure 7](#) for ELT P/N S1819502-02.

- (a) Put back the battery pack (3) into its housing (4)
- (b) Check that the O-ring (5) of lower cover is still in place.
- (c) Install the lower cover (2) in the correct assembly direction (the ear of the lower cover points to the front of the ELT) and install the eight screws (1)
- (d) Tighten the screws (1) of the lower cover
 - All ELTs except P/N S1819502-02, tighten the eight screws (1) in the sequence shown figure 6 to a torque of $0.9 + 0, -0.1$ Nm ($7.97 +0, -0.89$ lbf.in)
 - ELT P/N S1819502-02, tighten the nine screws (1) in the sequence shown figure 7 to a torque of 1.8 Nm (15.9 lbf.in)



*Figure 7: ELT lower cover
(Except for P/N S1819502-02)*

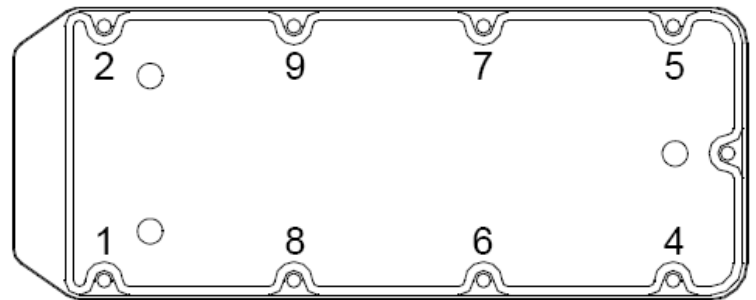

*Figure 8: ELT lower cover
(For P/N S1819502-02 Only)*

(2) Check of the ELT Tightness

- (a) Submerge the ELT vertically in a tank that contains enough water at 60 degrees Celsius \pm 5 degrees Celsius to cover the ELT. Gently shake the ELT whilst it is submerged to ensure that all surface and trapped air escapes from the ELT.
- (b) Make sure that, after 5 minutes, no string of air bubbles is released from
 - a. the bearing surfaces of the seals;
 - b. the side that has the connectors, the switch and the LED;
 - c. the attaching points (screws).
- (c) Take the ELT out of the water and dry it.
NOTE: Some air bubbles can escape, in particular those caught in the hollow areas of the shaped edge. If there is a leak, remove the ELT from the water rapidly and open it to remove all signs of moisture, then find the cause of the leak and correct as necessary.

8. PAPERWORK

- Update the inspection label with inspection date (today date) in MM/YYYY format.
- Update the next control date according to your regulation (MM/YYYY).

Oroliá S.A.S. does not require any other paperwork. Refer to your local regulation for other paperwork requirements.

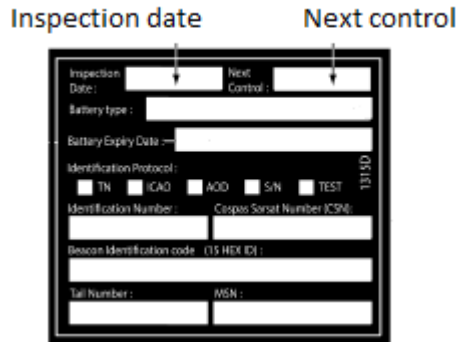

Figure 9: Identification / Inspection label

9. CONTACT

For any further information, please feel free to contact our customer support at:

Oroliá S.A.S.
 Customer Service
 Zone Industrielle des Cinq Chemins CS10028
 56520 GUIDEL
 FRANCE
 E-mail: support.sar@orolia.com
 Tel.: +33 (0)2 97 02 49 00