

The information and instructions contained in this document have been produced in accordance with Alternative Procedure to DOA EASA AP058.

COMPACT ELTs Family / INTEGRA ELTs Family GUIDELINES FOR PERIODIC INSPECTION

1. REASON

Testing the various elements of KANNAD ELTs is mandatory at each battery replacement (approximately 6 years interval). The only periodic check required by Orolia is the monthly self-test as described in the Installation/Operation manual. However, some Civil Aviation Authorities may require the ELT be tested periodically.

Periodicity and List of applicable tests are defined by local regulations.

The following guidelines are provided by Orolia to describe usual operations required by major Aviation Authorities.

It is the responsibility of the Customer to determine which tests are applicable to its ELT.

NOTE: This Service Letter supersedes SL S1840501-25-05

2. EFFECTIVITY

This Service Letter is applicable to the ELTs manufactured by OROLIA, listed below:

DESIGNATION	P/N
KANNAD 406 AF-COMPACT	S1840501-01
KANNAD 406 AF-COMPACT (ER)	S1840501-04
AP INTEGRA (ER)	S1850501-01
AP INTEGRA	S1850501-02
AP INTEGRA (ER-N)	S1850501-03
AF INTEGRA (ER)	S1851501-01
AF INTEGRA	S1851501-02
AF INTEGRA (ER-N)	S1851501-03
AF-H INTEGRA (ER)	S1852501-01
AF-H INTEGRA	S1852501-02
AF-H INTEGRA (ER-N)	S1852501-03
AP-H INTEGRA (ER)	S1854501-01
AP-H INTEGRA	S1854501-02
AP-H INTEGRA (ER-N)	S1854501-03

3. DESCRIPTION

A. USA (FAA)

The following regulation applies to the USA

USA: FAR 91.207 paragraph (d):

«Each emergency locator transmitter [...] must be inspected within 12 calendar months after the last inspection for --

- (1) Proper installation;*
- (2) Battery corrosion;*
- (3) Operation of the controls and crash sensor; and*
- (4) The presence of a sufficient signal radiated from its antenna. »*

B. CANADA (TCCA)

The following regulation applies to CANADA

CAR Part VI - Standard 625 Appendix C – 12 (b)(l):

ELTs [...] shall be maintained at intervals not exceeding:

- (A) 12 months, in accordance with the applicable operational test requirement in Appendix G of Standard 571; and*
- (B) 24 months, in accordance with the applicable performance test requirement in Appendix G of Standard 571.*

CAR Part V - Standard 571 Appendix G:

Maintenance of Emergency Locator Transmitters (ELTs)

(3) Operational Test [...]

(3)(a) [...] ELT Self-test [...]

(4) Performance Test [...]

(4)(b)(i) Inspection of the ELT [...]

(4)(b)(ii) measured peak power of the 406 MHz and 121.5 MHz transmissions [...]

(4)(b)(iii) measured frequencies of the 406 MHz and 121.5 MHz transmissions [...]

(4)(b)(iv) verification of 406 MHz digital message [...]

(4)(b)(v) 121.5 MHz audio modulation [...]

(4)(b)(vi) measured current draw [...]

(4)(b)(vii) test of the automatic activation system [...]

C. EUROPE (EASA)

The following regulation applies to EUROPE

SIB 2019-09R1:

EASA recommends that [...] operators [...] accomplish on an annual basis [...] a visual inspection of the ELT(AF) and ELT(AP) combined with a test and an inspection [...]

- *ELT installation [...]*
- *Absence of battery defect [...]*
- *[...] absence of wear [...]*
- *G-switch operation;*
- *Transmitted power and frequencies.*

D. Other Countries

Other countries: refer to local regulations

E. Special Airworthiness Information Bulletin

NOTE: SAIB HQ-12-32 is only applicable to Automatic Fixed (AF) and Automatic Portable (AP) ELTs.

Special Airworthiness Information Bulletin (SAIB) HQ-12-32 has informed emergency locator transmitter manufacturers as well as installers and aircraft maintenance personnel of a concern with the ability of hook and loop style fasteners to retain their designed capability to restrain emergency locator transmitters during accident impact. In several recent aircraft accidents, ELTs mounted with hook and loop style fasteners, commonly referred to as Velcro®, have detached from their aircraft mounting. The separation of the ELT from its mount caused the antenna connection to sever, rendering the ELT ineffective.

For ELT manufacturers who previously utilized hook and loop style fasteners for ELT retention, FAA recommends they include the following information in their ICA:

- 1. Instructions for properly securing the ELT during installation and reinstallation as well as a method to determine the appropriate tension of the hook and loop style fasteners.*
- 2. Instructions for inspecting hook and loop style fasteners for wear, contamination, environmental degradation, or other effects to ensure they will continue to meet the requirements in the applicable TSO. Incorporating this inspection with the inspection required by 14 CFR § 91.207 is appropriate.*
- 3. Replacement interval for the hook and loop style fasteners.*

CAUTION: AN INCORRECT TIGHTENING OF THE HOOK AND LOOP FASTENER COULD LEAD TO AN UNSAFE SITUATION PREVENTING THE TRANSMISSION OF THE DISTRESS MESSAGE BY THE ELT.

For further information refer to Orolia Service Bulletin "SB S1800000-25-00_Rev01 All KANNAD ELTs. Check of straps for mounting mechanisms". This Service Bulletin is available on Support page of Orolia Web site.

4. TOOLS

A. Standards and Specific Tools

Depending on the tests to be performed, the following tools may be required:

- 50 Ohm BNC Load, 1 Watt.
- Torque-limiting driver with Torx T10 bit
- COSPAS-SARSAT Decoder [any decoder capable to decode a COSPAS-SARSAT digital message compatible with 406.028 MHz (KANNAD 406 AF-COMPACT) or 406.037 MHz (INTEGRA ELTs) frequency, also called "Beacon Tester"]. Example: BT200-1100 or IFR4000 opt 1.
- 121.5 MHz VHF receiver (Aircraft VHF receiver may be used).
- Frequency meter (or any device able to measure the frequency of the 121.5MHz. Example BT200-1100 or IFR4000 opt 1)
- Wattmeter (or any device able to measure the power of the 121.5MHz. Example BT200-1100 or IFR4000 opt 1)
- Digital voltmeter with min/max recording.
- Annual inspection kit P/N S1840510-02 (see below) and/or tank capable to contain enough water to perform a water-tightness test if the ELT is opened.

The following tools are required only if current draw measurement is performed:

- 6.5 V_{DC} power supply, current 5 A.
- Plug, 2-pin female VHR-2N JST and 2x Pin female: SVH-21T-P1.1 JST
- Microammeter.

B. Annual Inspection Kit

NOTE: The use of the annual inspection kit is mandatory:

- if the ELT has to be opened and a water tightness test is not performed or,
- if the ELT has to be opened and the screws were damaged during removal, in this case they have to be replaced by screws available in the kit.

If a water tightness test is performed and if the screws are not damaged during removal, the use of annual inspection kit is recommended but not mandatory.

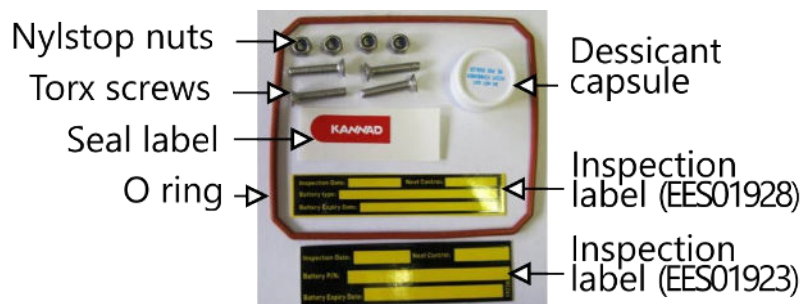

Figure 1: Annual inspection kit P/N S1840510-02

5. PROCEDURE ACCORDING TO FAR91.207 & EASA SIB No.: 2019-09R1

CAUTION: When actioning the ON/OFF/ARM switch, PULL LEVER TO UNLOCK and SET TO POSITION.

NOTE: Except when explicitly mentioned, always leave the switch in the "OFF" position during inspection.

A. Proper Installation

- (a) Remove the ELT from its mounting bracket (refer to relevant operation and installation manual).
- (b) Inspect the mounting bracket and the ELT: ensure the mounting bracket and the ELT are free of cracks or other obvious damage.
- (c) Check that the strap does not show traces of wear and tear due to ageing.
- (d) Inspect the connectors, cables and antennas (external and auxiliary in the case of AP ELT): visually inspect all pins of connector .
- (e) Do a visual check of the locking latches of the ON/OFF/ARM switch: make sure that the 4 locking latches are not damaged as described in Figure 2.

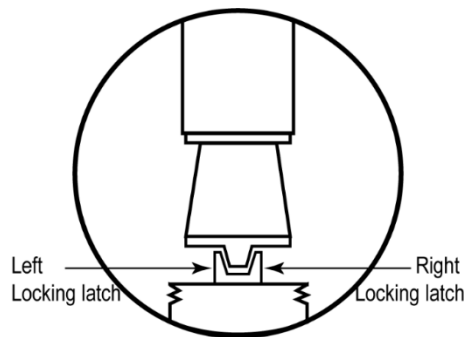

Figure 2: Locking latches of the ON/OFF/ARM Switch

B. Battery corrosion / Battery Voltage Measurement

IMPORTANT: The ELT is hermetically closed. Unless it is mandatory, Orolia recommends not opening the ELT.

Due to the technology used for Kannad ELTs and battery packs, any corrosion between two battery replacements is unlikely to happen. Orolia recommends an alternative way of checking the batteries by measuring the voltage of the battery without opening the ELT.

If it is mandatory to open the ELT for a visual inspection of the battery, refer to [Section 6 Operational Testing \(Every 12 Months\) - CAR Part V - Standard 571 Appendix G \(3\), E Disassembly](#) and [G Assembly](#)

(1) Battery voltage measurement

- (a) Connect a 50 Ohm load to the ANT receptacle.
- (b) Connect the digital voltmeter with max./min. recording between contacts G (RCP COMMON) and A (RCP RESET) of DIN-12 connector.

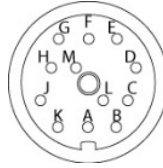

Figure 3: DIN-12 Connector Pin-out

- (c) Perform a self-test on the ELT (switch to ARM).
- (d) Measure the battery voltage with the digital voltmeter and check the voltage during the 406 MHz transmission.
- (e) Record the minimum voltage: the measured voltage must be more than 5.1 VDC
- (f) Return to the OFF position

NOTE: The minimum voltage must be recorded during the 406 MHz transmission (duration 440 ms for COMPACT ELTs or 520 ms for INTEGRA ELTs). If the MIN HOLD feature of the voltmeter is activated before the switch to ARM, the voltmeter will record ~0V as minimum voltage. The MIN HOLD must be activated right after the ELT has been switched to ARM.

C. Operation of the Controls and Crash Sensor

(1) Operation of controls and crash sensor for automatic ELTs

IMPORTANT: Do not operate for more than 50 seconds.

- (a) Connect a 50 Ohm load to the «ANT» receptacle.
- (b) Switch to ARM and wait for the end of the self-test.
- (c) Check operation of the crash sensor:
 - For KANNAD 406 AF Compact and AP / AF INTEGRA, cause abrupt move of the ELT towards the front (refer to flight direction arrows on upper label of ELT).
 - For AP-H INTEGRA and AF-H INTEGRA, cause abrupt move of the ELT towards the front with the ELT having a 45-degree upward tilt.
- (d) Make sure that the ELT operates (aural and visual indicator activated).
- (e) Switch the ELT to «OFF».
- (f) Disconnect the 50 Ohm Load.

(2) Operation of controls for automatic ELTs with RCP

This test is not required by EUROPE (EASA);

This test is to be performed with the Remote Control Panel (RCP).

- (a) Re-install the ELT onto its mounting bracket
- (b) Connect the outside antenna and RCP to the ELT.

- (c) Perform RCP operational tests:
Refer to Figure 4: Operation of controls with RCP.

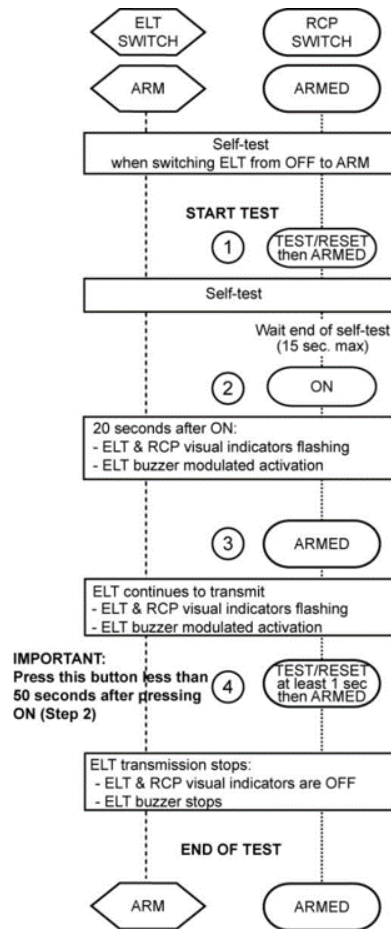

Figure 4: Operation of Controls with RC

D. Presence of a Sufficient Signal Radiated from its Antenna

- If not previously done during Operation of Controls, re-install the ELT onto its mounting bracket
- Connect the outside antenna to the antenna connector of the ELT.

(1) **406 MHz transmission test (optional on FAR91.207)**

Although this test is optional according to FAR 91.207, Orolia recommends performing this test if possible.

This test must be carried out with a COSPAS-SARSAT decoder.

When performed a few meters away from the ELT antenna, this test also validates the antenna radiation.

- Perform a self-test.
- Check the 15HEX ID displayed by the COSPAS SARSAT tester. It must be identical to the programmed 15HEX ID.

(2) 121.5 MHz transmission test

CAUTION: The short 121.5 MHz transmission may be received by a nearby control tower. According to your local regulations, it may be recommended to conduct this test during the first five minutes of any UTC hour.

This test must be carried out with a VHF receiver.

If the antenna was already validated with the 406 MHz transmission test (see above), the on-board aircraft VHF receiver may be used.

If a 406 MHz transmission test was not performed (no Cospas-Sarsat decoder) another VHF receiver must be used, placed at a distance of at least 10 meters (30ft.), in order to validate the antenna.

- (a) Check that the antenna is correctly connected.
- (b) Tune aircraft radio to 121.5 MHz and ensure you can hear it.
- (c) Switch from the "OFF" position to the "ARM" position or press RESET & TEST on the Remote Control Panel (ensure that the ELT switch is in the "ARM" position).
- (d) Close to the end of self-test a short (3-4 sweeps) 121.5 transmission is made. Check on the VHF receiver that the 121.5 signal is received with a strong level.

NOTE: at the end of the self-test, the test result is displayed with the red visual indicator and the buzzer will sound:

- One long flash indicates that the system is operational and that no error conditions were found.
- A series of short flashes indicates the test has failed.

The number of flashes gives an indication of the faulty parameter detected during the self-test:

- 3+1 LOW BATTERY VOLTAGE.
 - 3+2 LOW RF POWER.
 - 3+3 FAULTY VCO LOCKING (FAULTY FREQUENCY).
 - 3+4 NO IDENTIFICATION PROGRAMMED.
 - 3+5 FAULTY VSWR (LINK TO EXTERNAL ANTENNA), for INTEGRA ELTs only.
 - 3+6 INTERNAL GPS SERIAL LINK, for INTEGRA ELTs only
 - 3+7 INTEGRA ARINC e-NAV Faulty connection, for (ER-N) version only
- (e) Continue to listen to 121.5 MHz for a few seconds to ensure that the ELT does not continue to transmit after the test is terminated.

IMPORTANT: Do not allow test duration to exceed 5 seconds after the end of the self-test sequence. If the ELT operates for approximately 50 seconds, a 406 MHz signal is transmitted and is considered valid by the satellite system.

6. Operational Testing (Every 12 Months) - CAR Part V - Standard 571 Appendix G (3)

CAUTION: When actioning the ON/OFF/ARM switch, PULL LEVER TO UNLOCK and SET TO POSITION.

A. Self-test & 121.5 MHz transmission test

Refer to: [Section 5 -D Presence of a Sufficient Signal Radiated from its Antenna](#)

7. Performance Testing (Every 24 Months) - CAR Part V - Standard 571 Appendix G (4)

CAUTION: When actioning the ON/OFF/ARM switch, PULL LEVER TO UNLOCK and SET TO POSITION.

A. Inspection of the ELT

Refer to: [Section 5 A_Proper Installation](#)

B. Measured peak power, frequencies, digital message on the 406 MHz and 121.5 MHz transmissions

- (a) Connect the BNC connector of the ELT front panel to the BT200-1100 or any equivalent COSPAS-SARSAT tester.
- (b) Switch the ELT to ARM.
- (c) Measure these frequencies and power values
- (d) Transmission at 121.5
Frequency: 121.5 MHz \pm 0.006 MHz
Power: higher than +20 dBm (Compact) ; higher than +17 dBm (Integra)
- (e) Transmission at 406 MHz (one transmission at intervals of 50 seconds)
Frequency: 406.028 MHz \pm 0.001 MHz (compact) ; 406.037 MHz \pm 0.001 MHz (Integra)
Power: 37 dBm \pm 2 dB
- (f) Check the 15HEXID displayed by the COSPAS SARSAT tester. It must be identical to the programmed 15HEXID.
- (g) Switch the ELT to OFF.

C. Audio modulation

- (a) Connect the ELT to the beacon tester.
- (b) Switch the ELT from OFF to ARM.
- (c) Make sure that the modulation factor is between 85% and 100%.
- (d) Switch the ELT to OFF.
- (e) Disconnect the COSPAS-SARSAT tester

D. Automatic activation system

Refer to: Section 5 C(1)Operation of controls and crash sensor for automatic ELTs

E. Disassembly

IMPORTANT: Do not keep the ELT opened more than 2 hours if the annual inspection kit is not used (replacement of desiccant).

- 1) Remove the Front Panel assembly.
Refer to Figure 5

NOTE: discard screws (2), nuts (3), O-ring (6) and desiccant capsule (7) if the annual inspection kit is used.

- (a) Remove the four screws (2) and nuts (3) that hold the front panel assembly (1).
 - (b) Carefully extract the front panel assembly (1) up to reach the battery connector. NOTE: This will break the seal label (4).
 - (c) Disconnect the battery connector.
 - (d) Remove the front panel assembly (1) from the housing (5).
 - (e) Remove the O-ring (6) of the front panel assembly (1).
 - (f) Remove the desiccant capsule (7) from the foam (8).
- 2) Remove the battery pack (9) from the housing

CAUTION: NEVER REMOVE THE BATTERY BY PULLING THE WIRES.
 - 3) Check there are no traces of corrosion or other visible damage on the battery pack (9).

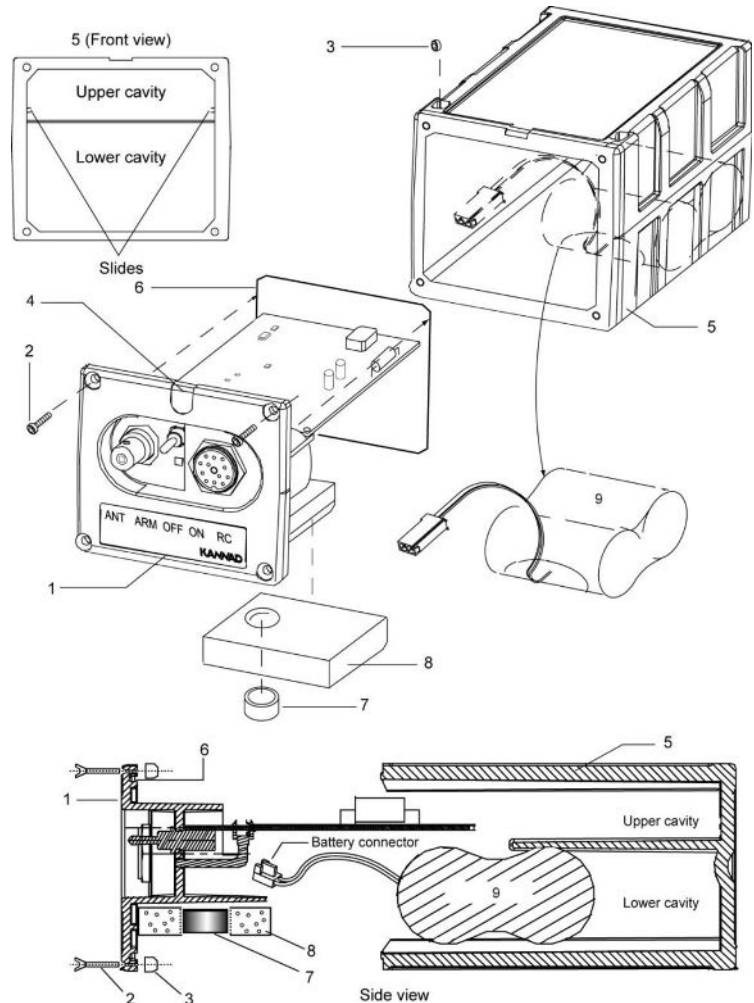

Figure 5: Opening / Closing the ELT

F. Measured current draw.

- (a) Connect a 50 ohms load to the ANT connector.
- (b) Set up the test model for current measurement (see figure below).
NOTE: the ELT battery pack can also be used instead of a 6.5 VDC power supply.

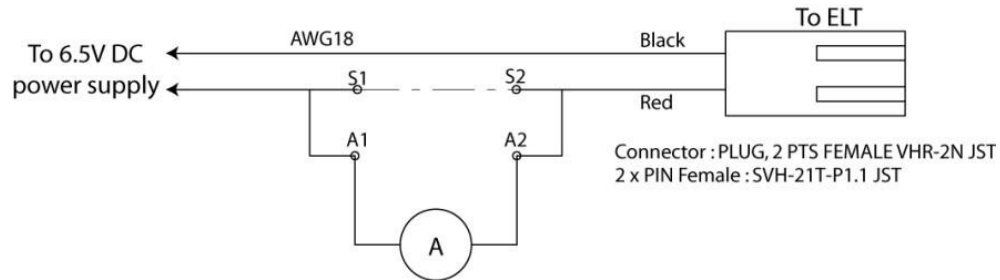

Figure 6: Test model for current measurement

- (c) Connect the 2 pins female plug of the test model to the electronic PCB.
- (d) Connect a microammeter to pins A1 and A2 of the test model.
- (e) Connect S1 to S2 (put a jumper).
- (f) Set the ELT to the ARM position: The ELT performs a self-test.
- (g) Disconnect S1 from S2 (remove the jumper).
- (h) Measure the standby current after the self-test procedure: Current must be less than 30 μA (Compact) or less than 10 μA (Integra)
- (i) Set the ELT to the OFF position.

G. Assembly

(1) **Reinstallation of the battery pack**

Refer to Figure 5

NOTE: Ensure that all parts (front panel, housing and O-ring are clean and dust-free).
Replace screws (2), nuts (3), O-ring (6) and desiccant capsule (7) if the annual inspection kit is used.

- (a) Install the battery pack (9) into the housing (5).
- (b) Insert the desiccant capsule (7) into the hole of the foam (8) stuck on the front panel.
- (c) NOTE: Install cardboard side of capsule towards PCB, plastic side towards lower part of the housing.
- (d) Clean the groove of front panel with dry compressed air (to remove dust).
- (e) Put the O-ring (6) into the groove of the front panel (1).

(2) Install the front panel assembly (1)

- (a) Connect the connector of the battery pack (9) to the electronic PCB of the front panel assembly (1).
- (b) Insert the front panel assembly (1) into the slides of the housing (5) and slide it into the housing taking care not to pinch the wires of the battery pack.
- (c) Screw the front panel assembly (1) to the housing (5) with the 4 screws (2) and nuts (3). Torque to 1 newton meter \pm 0.06 (8.85 pound-force inch \pm 0.53).
- (d) When using the annual inspection kit, affix a new seal label (4) onto the upper side of the front panel assembly and the housing.

(3) Check of the ELT Tightness

NOTE: ELT Tightness test is not mandatory when the annual inspection kit is used (Refer to [Section 4.B Annual Inspection Kit](#)).

- (a) Submerge the ELT vertically in a tank that contains enough water at $55\text{ }^{\circ}\text{C} \pm 5\text{ }^{\circ}\text{C}$ ($131\text{ }^{\circ}\text{F} \pm 9\text{ }^{\circ}\text{F}$) to cover the ELT. Gently shake the ELT whilst it is submerged to ensure that all surface and trapped air escapes from the ELT.
- (b) Make sure that, after 5 minutes, no string of air bubbles is released from
 - the bearing surfaces of the seals;
 - the side that has the connectors, the switch and the LED;
 - the attaching points (screws).
- (c) Take the ELT out of the water and dry it.
NOTE: Some air bubbles can escape, especially those caught in the hollow areas of the shaped edge. If there is a leak, remove the ELT from the water rapidly and open it to remove all signs of moisture, then find the cause of the leak and correct as necessary.

8. PAPERWORK

(a) Update the inspection label with inspection date (today date) in MM/YYYY format.

(b) Update the next control date according to your regulation (MM/YYYY).

Orolia does not require any other paperwork. Refer to your local regulation for other paperwork requirements.

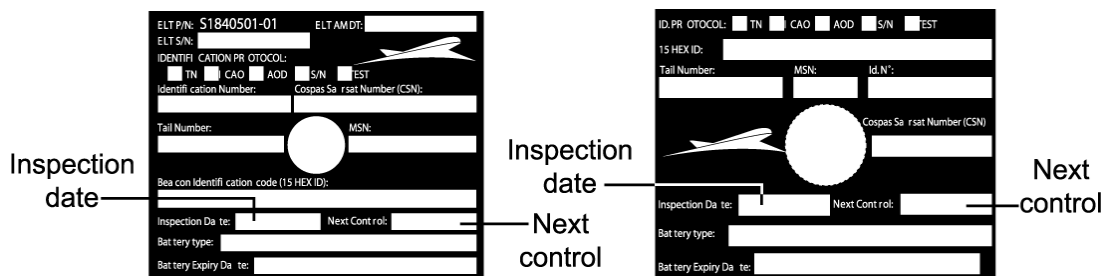

Figure 7: Identification / Inspection Label according to Date of Manufacture

Date: MAR 16/2020
Rev. 01

SL S18XX501-25-01

9. CONTACT

For any further information, please feel free to contact our customer support at:

OroliA S.A.S.
Customer Service
Z.I. des Cinq Chemins CS10028
56520 GUIDEL
FRANCE
E-mail: support.sar@orolia.com
Tel.: +33 (0)2 97 02 49 00

PAGE INTENTIONALLY LEFT BLANK